

Sine Pump

MR-Series

Installation & Operation Manual



COPYRIGHT

All rights reserved. No part of this publication may be reproduced, stored in a retrieval system or transmitted in any form or by any means, electronic, mechanical, photocopying, recording or otherwise without the prior permission of Sundyne Corporation.

© 2000 Sundyne Corporation

WARRANTY

Sundyne Corporation warrants to Buyer for a period of twelve (12) months from the date of being placed in service (but not to exceed eighteen (18) months after the date of shipment) that the equipment at the time of shipment will be free from defects of design, material and workmanship. If any defects or malperformance occur during the warranty period, Sundyne's sole obligation shall be limited to alteration, repair or replacement at Sundyne's expense, F.O.B. Factory, of parts or equipment, which upon return to Sundyne and upon Sundyne's examination prove to be defective. Equipment and accessories not manufactured by Sundyne are warranted only to the extent of and by the original manufacturers' warranty. Sundyne shall not be liable for damage or wear to equipment caused by abnormal conditions, vibration, failure to properly prime or to operate equipment without flow or caused by corrosives, abrasives or foreign objects. THE FOREGOING WARRANTY IS EXCLUSIVE AND IN LIEU OF ALL OTHER WARRANTIES, WHETHER EXPRESSED OR IMPLIED INCLUDING ANY WARRANTY OF MERCHANTABILITY OR FITNESS FOR ANY PARTICULAR PURPOSE. In no event shall Sundyne be liable for consequential or incidental damages.

Icons Used in this Manual

The following icons (symbols) are used to indicate specific types of information.



Good ideas to use. A reminder to do something.



Equipment use alert. Unless you follow these procedures correctly, the equipment may be damaged.



Safety alert. Failure to follow these procedures can endanger the safety of you or others.



Electrical hazard. Failure to follow these procedures can endanger the safety of you or others.

Contents

Important Safety Measures	5
Receiving Your Sine Pump	6
Installation Procedures	7
Figure 1 – Alignment	7
Operation Guidelines	8
Figure 1 – Nozzle Position.....	8
Figure 2 – Rotation	8
Wet End Disassembly	9
Wet End Assembly	11
Power End Disassembly.....	12
Power End Assembly	13
Seal System – Disassembly and Assembly	15
Figure 1 – Lip Seal	15
Table 1 – Press Plug Diameters.....	15
Table 2 – Press Plug Diameters.....	16
Figure 2 – O-ring Seal	16
Figure 3 – Mechanical Seal.....	17
Table 3 – Press Plug Diameters.....	17
Table 4 – Press Plug Diameters.....	18
Shimming for Proper Shaft Location	19
Scrapergate and Scrapergate Guide Installation Instructions.....	20
Pump Housing Rotation Instructions	22
Bearing Oil Lubrication Recommendations	23
Assembly Instructions for Installation of Front Cover Hinge	24
How to Use the Removal Tools.....	26
Torque Specifications	28
Sine Pump Weights	28
Troubleshooting the Sine Pump	29
Sine Pump Product Line.....	30
Sine Pump Software Material Guide	31
Seal Options – Cross Section and Parts	33

Contents (cont)

Cross Section and Parts (MR-120, MR-125, MR-130).....	36
Overall Dimensions (MR-120, MR-125, MR-130)	39
Cross Section and Parts (MR-135, MR-150).....	40
Overall Dimensions (MR-135, MR-150)	43
Cross Section and Parts (MR-135RF, MR-150RF).....	44
Overall Dimensions (MR-135RF, MR-150RF).....	47
General Notes	48
Parts Identifier Scheme	48
Material codes	49

Important Safety Measures



Note: It is important that this manual be read completely before attempting operation or disassembly of the SINE PUMP to ensure safety of personnel and to avoid damage to the pump.



Be sure to give strict attention to the Installation and Operation sections of this manual. These sections are intended to bring to the user's attention areas of bad practice that may give rise to possible failure conditions with the equipment as supplied.



Never place fingers, hands or other foreign objects into the Sine Pump during operation as this could cause personal injury.



Never operate the Sine Pump with the front cover removed or loose as this could cause fluid to spill out of the pump and could ultimately result in personal injury.



Do not operate the Sine Pump without the coupling guard installed properly. Clothing, body parts, tools or other loose items coming in contact with the pump/drive shaft or coupling could result in severe personal injury or loss of life.



Before attempting to dismantle the Sine Pump, be sure that the power source to the drive is disconnected or locked out. Ensure that the electrical switch gear cannot be operated while any work is being done on the pump.

Receiving Your Sine Pump

NOTE: Your Sine Pump has been inspected at the factory prior to shipment. All pumps are shipped ready for service, i.e. completely assembled. The bearing housings have been supplied with oil in them.

Inspect the shipping container and pump for evidence of damage during shipment.

If damage is found:

1. Note the extent of the damage before unpacking the pump.
2. Photograph the damage, as this is very helpful in making any claims against the carrier.

A pump lost or damaged during shipment is the responsibility of the carrier. Sundyne will assist in tracing any lost shipments.

After uncrating your Sine Pump:

1. Check to be sure that the suction and discharge nozzles are covered. If the nozzles protective covers have come loose or have been removed during shipment, it is important that the pump interior be inspected. Any debris found in the pump should be removed.
2. Check the nameplate data against the shipping papers and against your purchase order to insure that the proper pump has been provided and that the materials of construction match your specifications.
3. If applicable, check to see that the proper drive has been supplied, particularly with regard to the supply voltage required.
4. Inspect the suction and discharge nozzles to be certain that they are free of scratches and that they are clean of any foreign substances. The gasket seating surfaces should be inspected carefully, especially for vacuum and suction lift applications.
5. Liner/seal housing removal tools have been provided to assist you with maintenance of the Sine Pump. These tools (there should be two) can be found in the crating.

If there are any questions regarding receiving your pump, please contact Sine Pump at 303-425-0800.

Installation Procedures

NOTE: Before attempting to operate your Sine Pump, work through the following items.

1. Check the coupling alignment between the drive and the pump. This should be done only after the pump, drive and base have been fully anchored. Refer to Figure 1 and the alignment sheet supplied with the coupling, if applicable.

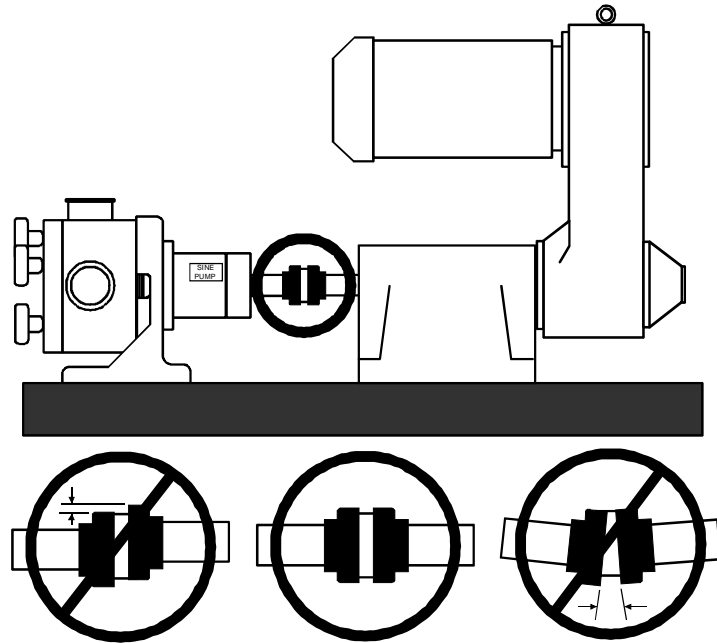

Figure 1 - Alignment

2. Be sure that the piping loads on the suction and discharge nozzles are not excessive. Flexible connectors on both the suction and discharge side of the pump are recommended to eliminate pipe stress or movement.
3. Check to be sure that the pump and piping are free of foreign objects.



Caution: Do not use the Sine Pump to flush or clean the piping system as damage to the pump may result.

4. Be sure to check all joint and piping connections to insure that they are tight and free of air leaks. Suction leaks can cause the pump to run inefficiently.
5. Pressure gauges on both the suction and discharge side of the pump are highly recommended. These gauges can often identify the source of system operational problems

1. Operation Guidelines

The following guidelines are important to the proper operation of your Sine Pump:



1. Check to be sure that the drive shaft rotation is compatible with the desired rotation of the pump shaft.
2. The suction and discharge nozzles on the pump housing will always remain 90° apart. However, the pump housing can be rotated in 45° increments to suit your desired nozzle positioning and process needs. Refer to Figure 1 for the three positioning options and to page 22 for instructions on how to rotate the pump housing.

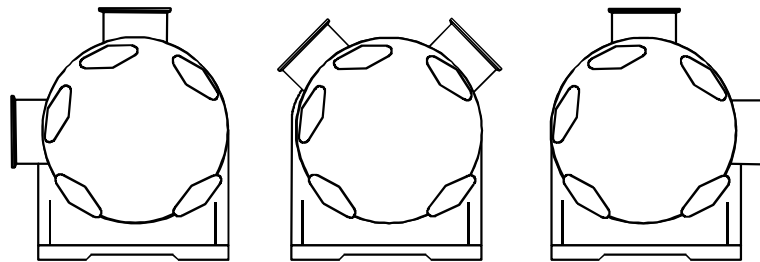

Figure 1

3. The application suction conditions determine the rotation of the pump shaft and the orientation of the scrapergate and scrapergate guide.

NOTE: The Sine Pump can operate in either a clockwise or counterclockwise direction with equal performance provided the scrapergate and scrapergate guide are installed properly. The fluid will pass through a 270° arc that will transport it from suction to discharge. Refer to Figure 2 and page 20 for scrapergate and scrapergate guide installation instructions.

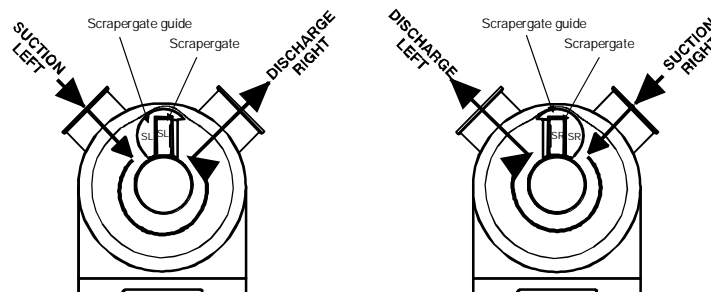

Figure 2



4. Caution: Do not run the Sine Pump dry. Damage to the wet end parts may result. If using the Sine Pump in conjunction with a variable speed drive, it is recommended to start the drive at as low a speed as possible. Be certain that liquid is available to the suction side of the pump before operating.



5. On suction lift applications, top suction nozzle orientation should be avoided, as it is very difficult to remove air from the pump in this position. It is necessary to fill the pump with water or product prior to starting the drive.

Operation Guidelines, cont.



6. Be certain that all suction and discharge valves lines, etc. in the system are open and clear of any clogs. This will prevent over pressurization of the pump. Warning: The Sine Pump is not supplied with a relief valve and the maximum discharge pressure rating is 150 psi. Exceeding this maximum pressure rating could result in severe personal injury.



7. The maximum Sine Pump operating speeds are:

MR-120
800 RPM

MR-125
800 RPM

MR-130
800 RPM

MR-135/MR-135RF
600 RPM

MR-150/MR150RF
600 RPM



Warning: Exceeding the maximum speed rating for your Sine Pump could result in severe personal injury or loss of life. Since some pumpages may be adversely affected by operation at high rotor speeds, we recommend that you contact Sine Pump with pertinent application information before running at or near these speeds.



8. It is recommended that the Sine Pump wet end be fully disassembled for cleaning after every use per the instructions in the Wet End Disassembly section of this manual. Sanitizing the Sine Pump in a Clean-In-Place (CIP) system with a common disinfecting or rinsing solution may not fully clean the wet end of the pump.



9. Warning: When pumping explosive, flammable or hazardous fluids, please contact the factory for application assistance.

10. The Sine Pump airborne noise emissions do not exceed 70 dB(A).

Wet End Disassembly

Reference the isometric drawing below for parts identification while following the wet end disassembly and assembly steps.

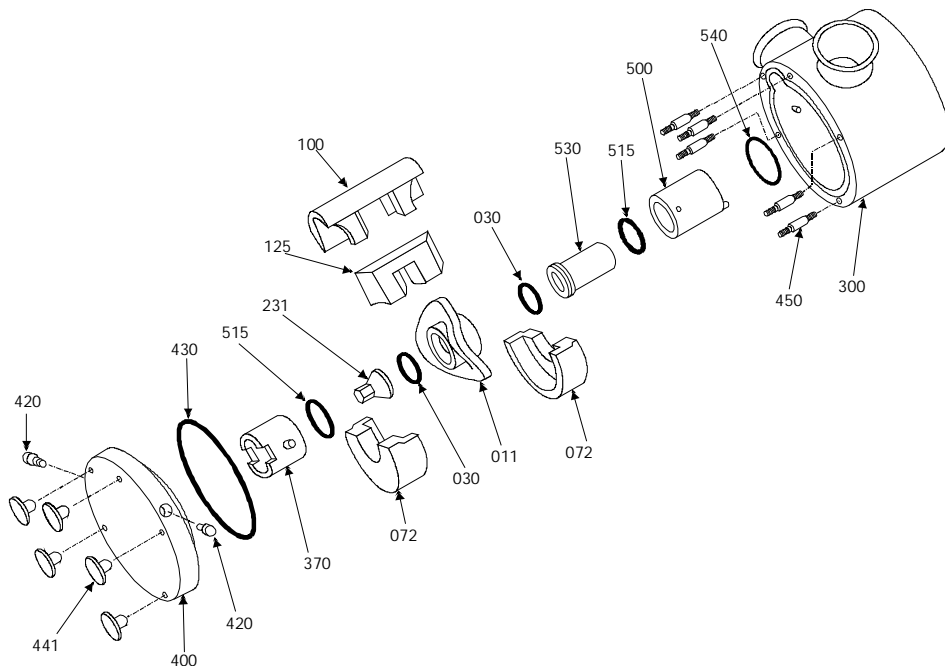

Wet End Disassembly, cont.



1. Remove the front cover, item 400, by removing the five wing nuts, item 441, and sliding the cover off of the front cover studs, item 450. **NOTE: Do not use a screwdriver or other prying instrument to separate the cover from the housing. Damage to the stainless steel may result.** A soft hammer can be used to separate the cover from the housing by tapping on the front cover pins, item 420, located on the outer diameter of the front cover.

2. The front support, item 370, may now be removed from the front cover for inspection and cleaning. If the support is stainless steel, remove the dynamic face o-ring, item 515, from the groove.



3. Remove the front liner, item 072, by pulling with even pressure on both ends. Pulling with uneven pressure may cause the liner to become lodged in the pump housing making it difficult to remove. **NOTE: Pumping of high temperature fluids may also make the liners difficult to remove due to thermal expansion.** If the pump has been running at a high temperature, allow it to cool before removing the liner.
4. Remove the shaft nut, item 231, from the shaft, item 200. Wrench flats have been machined on the rear of the shaft for the purpose of securing the shaft while removing the nut. The rotor o-ring, item 030, can now be removed from the groove in the shaft nut.
5. Next, the rotor, item 011, the scrapergate, item 125, and the scrapergate guide, item 100, can be pulled off the shaft and removed from the pump housing. This will require two hands.
6. Remove the rear liner, item 072. This is where the liner/ seal housing removal tools will be helpful (refer to page 26-27). Insert the hooked ends of the liner pullers into the slots located on each end of the liner. Again, apply even pressure on both ends to prevent the liner from lodging the pump housing.
7. The lip seal housing, item 500, may now be removed, along with the shaft sleeve, item 530. The liner/seal housing puller tools should be used here again (refer to pages 26-27). Simply insert the pins on the pullers into the holes in the outer diameter of the seal housing, located 180° from each other, and use the tool to lever the seal housing out of the pump housing. Refer to page 33-35, Seal Options, for a diagram showing your specific seal arrangement. If the seal housing is stainless steel, remove the dynamic face o-ring, item 515, from the groove. For further disassembly procedures for your specific seal arrangement, refer to the seal system disassembly section of this manual.
8. Remove the shaft sleeve, item 530, from the seal housing. The rotor o-ring, item 030, can then be removed from the groove in the shaft sleeve.
9. The seal housing o-ring, item 540, may then be removed from the groove in the pump housing. There is a small notch in the bore of the pump housing to facilitate easy removal of the o-ring.
10. Should removal of the pump housing, item 300, be required, remove the housing mounting bolts, item 340, and housing mounting washers, item 345, which connect the pump housing to the power frame, item 600. **Warning: Suitable lifting equipment should be used when removing the pump housing to ensure that personal injury or damage to pump components does not occur.**



Wet End Assembly



1. Place the pump housing, item 300, onto the power frame, item 600, by fitting the opening in the back of the pump housing over the shaft, item 200. NOTE: Be sure that the mating flanges of the power frame and pump housing are free of any debris or nicks, as this may cause misalignment of the rotor. **Warning: Suitable lifting equipment should be used when installing the pump housing to ensure that personal injury or damage to pump components does not occur.**
2. Install the housing mounting washers, item 345, and housing mounting bolts, item 340, through the rear of the power frame. The bolts should be tightened evenly and to the torque specification provided on page 28.
3. Replace the seal housing o-ring, item 540, by fitting it into the groove in the rear of the pump housing. Apply a food grade lubricant to the o-ring before installation.
4. If the lip seal housing, item 500, is stainless steel, replace the dynamic face o-ring, item 515, by placing it into the groove at the end of the seal housing. Apply a food grade lubricant to the o-ring before installing. Place the seal housing into the bore in the rear of the pump housing, item 300, such that the removal holes on the outer diameter are exposed. NOTE: Lubricating the outer diameter of the rear of the seal housing will promote easy assembly with the seal housing o-ring, item 540. If the seal housing is stainless steel, the anti-rotation pin in the rear of the seal housing must be sealed properly in the slot in the rear of the pump housing. To properly seat the seal housing, place the rotor, item 011, and the shaft nut, item 231, over the shaft, item 200. Tighten the shaft nut to force the seal housing past the seal housing o-ring. Remove the rotor and shaft nut from the shaft before proceeding. For further assembly procedures for your specific seal arrangement, refer to the seal system assembly section of this manual.
5. Replace one of the rotor o-rings, item 030, by placing it into the groove on the end of the shaft sleeve, item 530. Apply a food grade lubricant to the o-ring before installing. The shaft sleeve may then be fitted over the shaft and into the seal housing.
6. Install one of the liners, item 072, into the pump housing being sure to fit the liner between the two anti-rotation pins located on the internal diameter of the pump housing. Apply even pressure to both ends to prevent the liner from becoming lodged in the pump housing.
7. Place the scrapergate, item 125, into the scrapergate guide, item 100, being sure that the marked ends (SL and SR) match up properly. Referencing page 20 of this manual, place the scrapergate and scrapergate guide in the desired orientation. Using both hands, this assembly can then be placed on the rotor, item 011, such that the opening in the scrapergate and scrapergate guide fit over the rotor vane. Install this three-piece assembly in the pump by placing the scrapergate guide into the bore located between the suction and discharge nozzle and fitting the rotor over the splined section of the shaft. NOTE: There is no front or back to the rotor, so it can be inserted either way. Once the rotor meets the rotor o-ring on the shaft sleeve, apply extra pressure to insure that the rotor is seated over the o-ring.
8. Replace the other rotor o-ring, item 030, by placing it into the groove on the end of the shaft nut, item 231. Apply a food grade lubricant to the o-ring before installing. The shaft nut can then be tightened onto the shaft. Wrench flats have been machined on the rear of the shaft for the purpose of securing the shaft while tightening the shaft nut. Torque the shaft nut to the specification listed on page 28.
9. Install the other liner, item 072, into the pump housing being sure to fit the liner between the two anti-rotation pins located on the internal diameter of the pump housing. Apply even pressure to both ends such that the liner does not become lodged in the pump housing.

Wet End Disassembly, cont.

10. The front cover o-ring, item 430, can then be placed into the groove on the front of the pump housing. Applying a food grade lubricant to the o-ring will keep it from slipping out of the groove.
11. If the front support, item 370, is stainless steel, replace the dynamic face o-ring, item 515, by placing it into the groove at the end of the front support. Apply a food grade lubricant to the o-ring before installing. Place the front support into the bore in the front cover, item 400, with the slots being installed first.
12. Place the front cover and front support assembly onto the front of the pump housing by lining up the front cover studs, item 450, with the corresponding holes in the cover. Front cover pins, item 420, have been placed on the outer diameter of the front cover to facilitate this.
13. Install the five wing nuts, item 441, by hand tightening them onto the front cover studs. The wing nuts may be further tightened with a soft-headed hammer. **NOTE: If the front cover does not seat properly against the pump housing face, remove the cover and examine the internal components checking for proper alignment.**



Power End Disassembly

Reference the isometric drawing below for parts identification while following the power end disassembly and assembly steps.

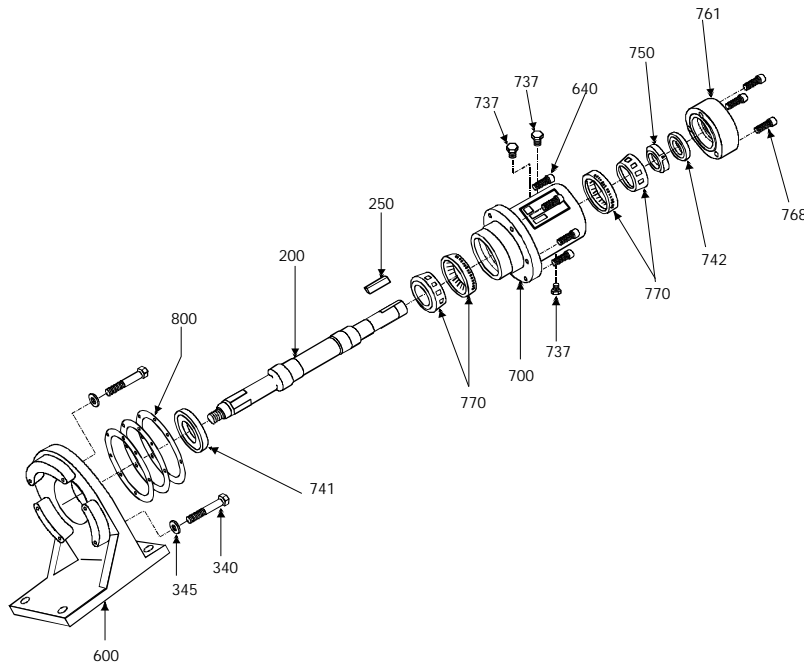

1. Before beginning the power end disassembly, follow steps 1 through 11 in the wet end disassembly section of this manual.
2. Drain the oil from the bearing housing, item 700, by removing the oil drain plug, item 737, located on the bottom of the bearing housing.

Power End Disassembly, cont.



3. Remove the bearing housing mounting cap screws, item 640, which connect the bearing housing, item 700, to the power frame, item 600. The bearing housing may then be removed by pulling the shaft, item 200, and bearing housing away from the power frame. **NOTE: Be sure to support the bearing housing such that the shaft will not be damaged when pulling it through the hole in the power frame.**
4. Remove the shims, item 800, which are located where the bearing housing meets the power frame.
5. Remove the bearing housing cover cap screws, item 768, which connect the bearing housing cover, item 761, to the bearing housing. The bearing housing cover can then be removed.



6. Using a punch and hammer or a press, remove the outboard oil seal, item 742, from the cover. **NOTE: Be careful not to damage the bearing housing cover when removing the seal.**
7. Loosen the four small set screws located in the bearing locknut, item 750. The bearing locknut can then be unscrewed and removed from the shaft.



8. Using a press, remove the shaft from the bearing housing by applying force to the key end of the shaft. As the shaft is being forced out of the bearing housing, the rear tapered roller bearing inner race, item 770, is being removed from the shaft. **NOTE: The shaft will come free and drop out of the bearing housing when the bearing is pressed out. Be sure to support the shaft such that it will not be damaged.**
9. Remove the inboard oil seal, item 741, by simply pulling it off of the shaft.
10. Remove the front tapered roller bearing inner race, item 770, by pressing the bearing off of the shaft.



11. Using a punch and hammer or a press, remove the front and rear tapered roller bearing outer races, item 770, from the bearing housing. **NOTE: Be careful not to damage the internal diameter of the bearing housing when removing the outer races.**

Power End Assembly



1. Press the front and rear tapered roller bearing outer races, item 770, into the bearing housing, item 700, being sure that the angled ends of the races face out of the housing. In the case of the MR-150 and MR-150RF, the larger of the two outer races should be pressed into the flanged end of the bearing housing. **NOTE: Be careful not to damage the race surfaces, as this may lead to premature bearing failure.**



2. For easy bearing assembly, lock the shaft, item 200, into a vertical position with the key end of the shaft on top. Heat one of the tapered roller bearing inner races (in the case of the MR-150 and MR-150RF, the larger of the two bearings), item 770, to a temperature of 250°F. Thermal expansion of the bearing will allow it to fit into the shaft. **NOTE: Do not overheat the inner race, as this will distort the roller support. While the bearing is hot, fit it onto the shaft until it reaches the step, with the tapered section facing upward.**
3. Place the bearing housing, item 700, flanged section first, over the shaft. This will seat the front bearing inner and outer races.
4. Heat the other tapered roller bearing inner race, item 770, to a temperature of 250°F. While the bearing is hot, place it onto the shaft with the tapered section facing down into the bearing housing. This will seat the back bearing inner and outer races.

Power End Assembly, cont.



5. With the bearing still hot, tighten the bearing locknut, item 750, onto the shaft, only enough to eliminate any float between the shaft and the bearing housing. **NOTE: The holes for the set screws must be facing upward or out of the bearing housing when the bearing locknut is installed. While tightening the bearing locknut, rotate the bearing housing a few times to insure that the bearings have seated properly.**
6. After allowing the assembly to cool, tighten the bearing locknut until the torque required to turn the shaft falls within the following range of your specific pump model:

MR-120 and MR-125	=	1 to 3 in lbs
MR-130 and MR-135 and MR-135RF	=	6 to 8 in lbs
MR-150 and MR-150RF	=	8 to 10 in lbs



This requires tightening the shaft nut, item 231, onto the shaft, item 200, and using a torque wrench to measure the torque required to turn the shaft. **NOTE: Remember, this is the torque required to turn the shaft. The actual torque required to turn the bearing locknut is much greater.**

7. Tighten the four set screws on the bearing locknut.
8. Press the outboard oil seal, item 742, into the bearing housing cover, item 761, with the lip section of the seal facing outward. Be sure to lubricate the inner and outer diameter of the lip seal.
9. Apply a quality gasket sealant to the mating surface of the bearing housing cover, item 761, and the bearing housing, item 700. Fit the bearing housing cover onto the bearing housing while lining up the holes for the bearing housing cover cap screws, item 768. Fit the bearing housing cover cap screws into the holes and tighten to the torque specification provided on page 28.



10. Press the inboard oil seal, item 741, into the bearing housing by fitting it, lip section first, over the wet end of the shaft. **Be sure to lubricate the inner and outer diameter of the lip seal.**



11. Clean the mating surfaces between the bearing housing, item 700, and the power frame, item 600, to insure that no debris is between the parts. Fit the bearing housing onto the power frame while lining up the holes for the bearing housing mounting cap screws, item 640. The bearing housing must be oriented such that the drain plug, item 737, is located at the bottom. **NOTE: Be sure to support the bearing housing such that the shaft will not be damaged while fitting it through the hole in the power frame. Fit the bearing housing mounting cap screws into the holes and tighten to the torque specification provided on page 28.**

12. Install and tighten the drain plug, item 737.



13. Remove the oil fill plug and oil level plug, items 737. Fill the bearing housing with oil until the oil is visible through the level hole. Refer to page 23 for oil lubrication recommendations. **NOTE: Fill the bearing housing with oil only to the oil level hole, as overfilling may cause the bearings to fail prematurely. Replace and tighten the oil fill and oil level plugs.**



14. Before replacing the parts in the wet end of the pump, refer to page 19 for shimming instructions. **NOTE: The bearing housing must always be shimmed when the bearings are changed or the bearing housing is removed for the purpose of properly locating the rotor in the center of the pump.**

Seal System – Disassembly and Assembly

A. Lip Seal

Reference the isometric drawing in Figure 1 for parts identification while following the lip seal disassembly and assembly steps.

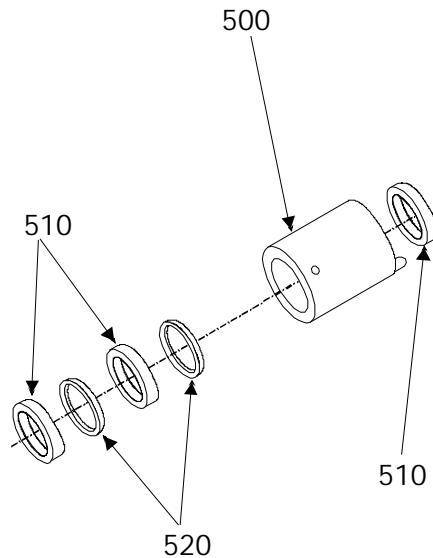

Figure 1 – Lip Seal

Lip Seal Disassembly



1. Using a punch and hammer, remove the single lip seal, item 510, located in the rear of the lip seal housing, item 500. **NOTE: Be careful not to damage the inner diameter of the housing when removing the seal.**
2. Turn the seal housing upside down and press the remaining two lip seals, item 510, and the two support rings, item 520, out of the seal housing using the press plug diameter for your specific model listed in Table 1. The lip seals should be discarded.

Table 1 - Press Plug Diameters

MR-120	=	1-3/8"	or	34.9 mm
MR-125	=	1-7/8"	or	47.6 mm
MR-130	=	2-3/8"	or	60.3 mm
MR-135	=	2-3/4"	or	69.8 mm
MR-150	=	3-1/2"	or	88.9 mm



NOTE: Be careful not to damage the support rings, as these will be used again.

Lip Seal Assembly

1. Apply a food grade lubricant to the inner diameter of the lip seal housing, item 500. This should be done to both ends of the housing.

Seal System – Disassembly and Assembly, cont.

2. Place the seal housing in a press with the removal holes at the top of the housing. This side of the seal housing will face into the wet end of the pump. Insert one support ring, item 520, into the seal housing such that the flat surface of the ring rests on the step in the housing. This will not require a press.
3. Press one of the lip seals, item 510, into the seal housing with the lip side of the seal facing out of the housing using the press plug diameter listed in Table 2 for your specific pump model. Press the seal in until it fits securely over the support ring.

Table 2 - Press Plug Diameters

MR-120	=	1-9/16"	or	39.6 mm
MR-125	=	2-7/32"	or	56.3 mm
MR-130	=	2-5/8"	or	66.6 mm
MR-135	=	3"	or	76.2 mm
MR-150	=	3-29/32"	or	99.2 mm



NOTE: Apply even pressure to the lip seal to prevent it from lodging sideways in the housing.

4. Insert the other support ring, item 520, into the seal housing such that the flat surface of the ring rests on the lip seal. This will not require a press.



5. Press the second lip seal, item 510, into the seal housing with the lip side of the seal facing out of the housing using the press plug diameter listed in Table 2 for your specific pump model. Press the seal in until it fits securely over the support ring. **NOTE: Apply even pressure to the lip seal to prevent it from lodging sideways in the housing.**



6. Turn the seal housing over such that the removal holes in the housing are at the bottom. This side of the seal housing will face the power end of the pump. Press the third lip seal, item 510, into the seal housing with the lip side of the seal facing out of the housing. Press the lip seal in until the flat side of the seal rests on the step in the seal housing. **NOTE: Apply even pressure to the lip seal to prevent it from lodging sideways in the housing.**

B. O-Ring Seal

Reference the isometric drawing in Figure 2 for parts identification while following the o-ring seal disassembly and assembly steps.

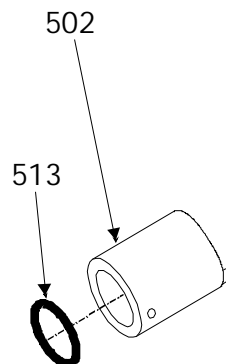

Figure 2 - O-Ring Seal

Seal System – Disassembly and Assembly, cont.

O-ring Seal Disassembly

1. Remove the dynamic radial o-ring, item 513, from the inner diameter of the o-ring seal housing, item 502.

O-ring Seal Assembly

1. Replace the dynamic radial o-ring, item 513, by placing it into the groove on the inner diameter of the o-ring seal housing, item 502. Apply a food grade lubricant to the inner diameter of the o-ring.

C. Mechanical Seal

Reference the isometric drawing in Figure 3 for parts identification while following the mechanical seal disassembly and assembly steps.

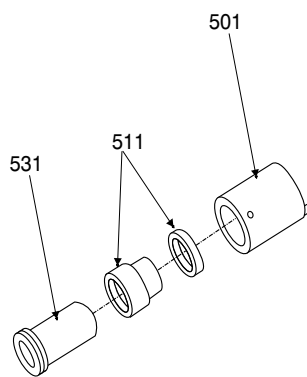

Figure 3 - Mechanical

Mechanical Seal Disassembly

1. Remove the shaft sleeve, item 531, from the mechanical seal housing, item 501. Slide the mechanical seal, item 511, off of the shaft sleeve.
2. To remove the stationary ceramic face of the mechanical seal, item 511, place the seal housing in a press with the removal holes at the bottom of the housing. Press the face out of the housing using the press plug diameter listed in Table 3 for your specific pump model.

Table 3 - Press Plug Diameters

MR-120	=	1-1/2"	or	38.1 mm
MR-125	=	1-3/4"	or	44.4 mm
MR-130	=	2-1/8"	or	53.9 mm
MR-135	=	2-1/8"	or	53.9 mm
MR-150	=	3-7/16"	or	87.3 mm

Mechanical Seal Assembly

1. Apply a food grade lubricant to the inner diameter of the mechanical seal housing, item 501.
2. Place the mechanical seal housing, item 501, into a press with the removal holes at the top of the housing. Press the stationary ceramic face of the mechanical seal, item 511, into the seal housing until it reaches the step at the rear of the housing using the press plug diameter listed in Table 4 for your specific pump model.

Seal System – Disassembly and Assembly, cont.

Table 4 - Press Plug Diameters

MR-120	=	1-5/8"	or	41.2 mm
MR-125	=	2"	or	50.8 mm
MR-130	=	2-5/8"	or	66.6 mm
MR-135	=	2-5/8"	or	66.6 mm
MR-150	=	3-5/8"	or	92.1 mm



It can be fitted in either way, as there is no front and back side. **NOTE: Apply even pressure to the stationary face so as not to damage the o-ring located on the outer diameter of the face.**

3. Install the mechanical seal, item 511, onto the shaft sleeve, item 531, such that the carbon face slides over the sleeve last. The slot on the end of the mechanical seal opposite the carbon face must be installed over the drive pin on the shaft sleeve.
4. Fit the mechanical seal and shaft sleeve assembly into the seal housing with the seal being installed first. This will mate the stationary ceramic face to the carbon face.
5. For instructions regarding the disassembly and assembly procedures for the double lip seal or the o-ring seal with flush, please contact Sine Pump Technical Services at 303-425-0800.

Shimming for Proper Shaft Location

Proper shaft location will insure that the rotor is positioned in the center of the wet end of the pump. Failure to position the rotor correctly may result in excessive and premature wear to the wet end parts. Here are the steps necessary to shim your Sine Pump.



1. Install the bearing housing, item 700, into the power frame, item 600, and tighten the bearing housing mounting cap screws, item 640. Install the pump housing, item 300, on the power frame and tighten the housing mounting bolts, item 340. The mating surfaces between the parts should be cleaned to eliminate any debris or burrs. **NOTE: Be sure that both the cap screws and bolts are tightened to the torque specification provided on page 28.**



2. Install the shaft sleeve, item 530, over the wet end of the shaft, item 200 as shown in Figure 1 below. The shaft sleeve should be pushed onto the shaft until it reaches the shoulder. The mating surfaces between the sleeve and the shaft should be cleaned to eliminate any debris or burrs.
3. Using a depth micrometer, or other tool which measures increments of 0.001", measure the dimension from the shoulder on the shaft sleeve to the back face of the pump housing as shown in Figure 1.
4. Subtract the measurement which you received in step 3 from the "X" dimension listed in the chart below for your pump model. The result will equal the amount of shim necessary to install between the bearing housing and power frame. **NOTE: If the dimensions listed are considerably different from your measurement, please contact Sine Pump Technical Services at 303-425-0800. Remove the shaft sleeve from the shaft. Loosen and remove the bearing housing mounting cap screws. Remove the bearing housing and shaft assembly from the power frame.**

5. Remove the shaft sleeve from the shaft. Loosen and remove the bearing housing mounting cap screws. Remove the bearing housing and shaft assembly from the power frame.

6. Install the correct thickness of shim, item 800, required to fit within the tolerance listed in the chart below for your pump model. Place the shim over the bearing housing flange such that the holes in the shim are lined up with the holes on the bearing housing flange.



7. Install the bearing housing into the power frame and tighten the bearing housing mounting cap screws. **NOTE: Be sure that the cap screws are tightened to the torque specification provided on page 28. Verify your measurements.**

Model	"X" Dimension
MR-120	0.938 + .001/- .000
MR-125	0.937 + .001/- .000
MR-130	1.217 + .001/- .000
MR-135/MR-135RF	1.059 + .001/- .000
MR-150/MR-150RF	1.311 + .001/- .000

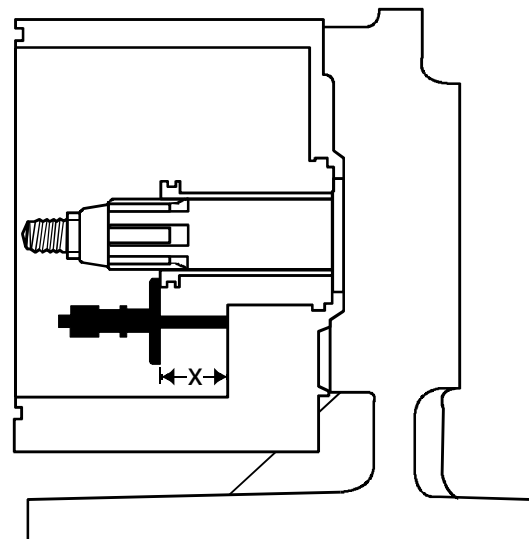

Figure 1.

Scrapergate and Scrapergate Guide Installation Instructions

The scrapergate has been designed with an angle on each of its ends and a channel on the discharge side for optimum performance and life span. It is used to separate the suction and discharge sides of the pump. To ensure proper operation, it is essential that these installation instructions be followed carefully.

The scrapergate has a suction side and a discharge side as shown in Figure 1. If viewed from the top, the scrapergate is wider on the suction side than on the discharge side. One of the angled ends of the scrapergate has been stamped "SL" for suction left and the other has been stamped "SR" for suction right. The scrapergate guide also has a suction side and a discharge side as shown in Figure 2. If viewed from the end, the scrapergate guide has a rounded, wider section which corresponds to the suction side and a thin, flat section which corresponds to the discharge side. The ends of the scrapergate guide has also been stamped with the markings "SL" and "SR".

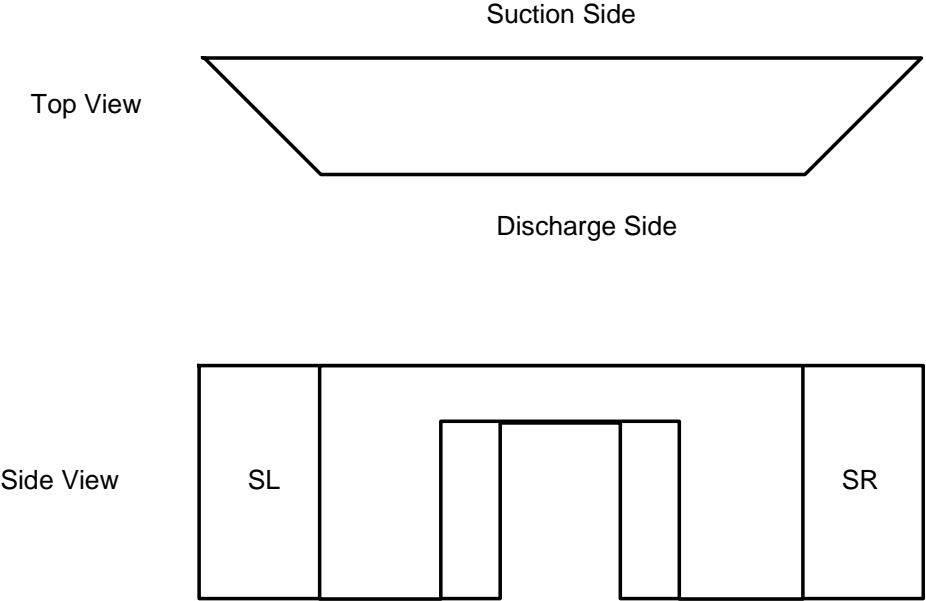

Figure 1 - Scrapergate

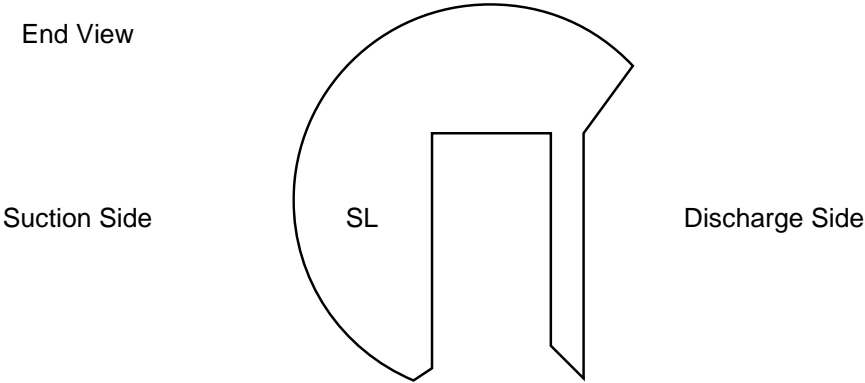

Figure 2 - Scrapergate Guide

Scrapergate and Scrapergate Guide Installation Instructions

When inserting the scrapergate into the scrapergate guide, the markings on the ends of both parts must match. This ensures that the wider side of the scrapergate will contact the wider section of the scrapergate guide.

Your suction conditions coupled with the nozzle orientation determine how the scrapergate and scrapergate guide should be installed in the Sine Pump. The two most common Sine Pump flow conditions are shown in Figure 4. When viewing the pump from the front (where the front cover is located), if the product were to enter the Sine Pump through the nozzle located at the 12 o'clock position and leave the pump through the nozzle located at the 3 o'clock position as depicted on the left in Figure 4, the suction left condition would apply. Thus, the scrapergate and scrapergate guide should be installed with the "SL" markings facing out towards the front cover of the pump. This corresponds to a counterclockwise rotation of the shaft.

When viewing the pump from the front, if the product were to enter the Sine Pump through the nozzle located at the 3 o'clock position and leave the pump through the nozzle located at the 12 o'clock position as depicted on the right in Figure 4, the suction right condition would apply. Thus the scrapergate and scrapergate guide should be installed with the "SR" markings facing out towards the front cover of the pump. This corresponds to a clockwise rotation of the shaft.

To change the orientation of the scrapergate and scrapergate guide, follow steps 1 through 6 of the Wet End Disassembly section of this manual. Rotate the scrapergate and scrapergate guide and then follow steps 7 through 13 of the Wet End Assembly section of this manual.

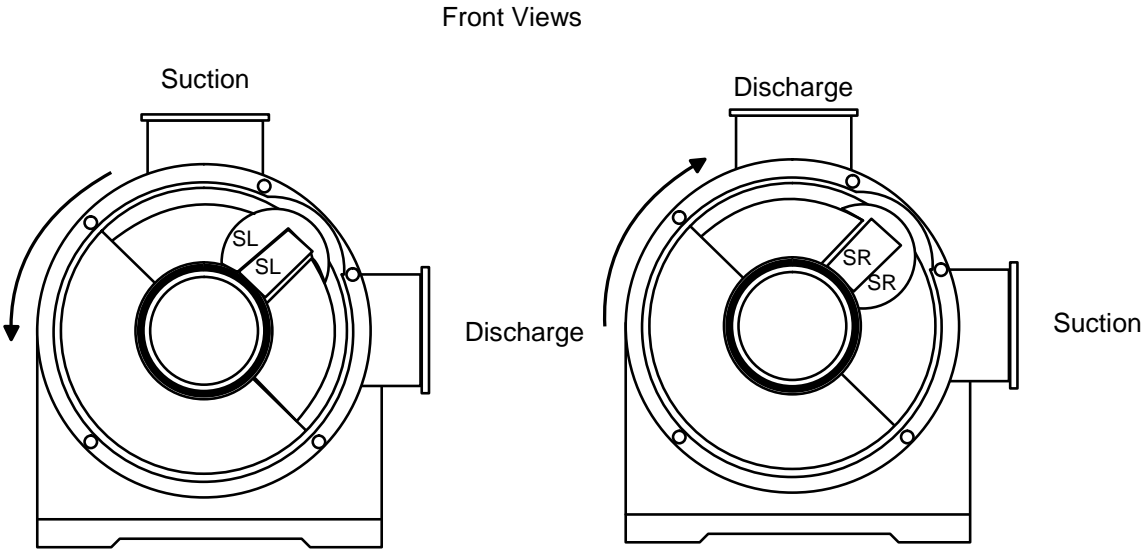

Figure 4

Pump Housing Rotation Instructions

The pump housing can be rotated to locate the inlet and outlet nozzles in the three different positions shown in Figure 1. This allows for six different operating conditions based on the rotation of the pump shaft. Figure 1 shows the various pumping orientations with arrows depicting shaft rotation. In the diagram, the inlet and outlet nozzles have been marked "S" to depict suction and "D" to depict discharge.

To rotate the pump housing to fit your inlet and outlet piping conditions, simply follow these instructions:

1. Remove all of the parts from the wet end of the pump. Refer to the Wet End Disassembly section of this manual.



2. Loosen and remove the housing mounting bolts, item 340, and the housing mounting washers, item 345, which attach the pump housing, item 300, to the power frame, item 600. **Warning: Suitable lifting equipment should be used when removing and installing the pump housing to ensure that personal injury or damage to pump components does not occur.**

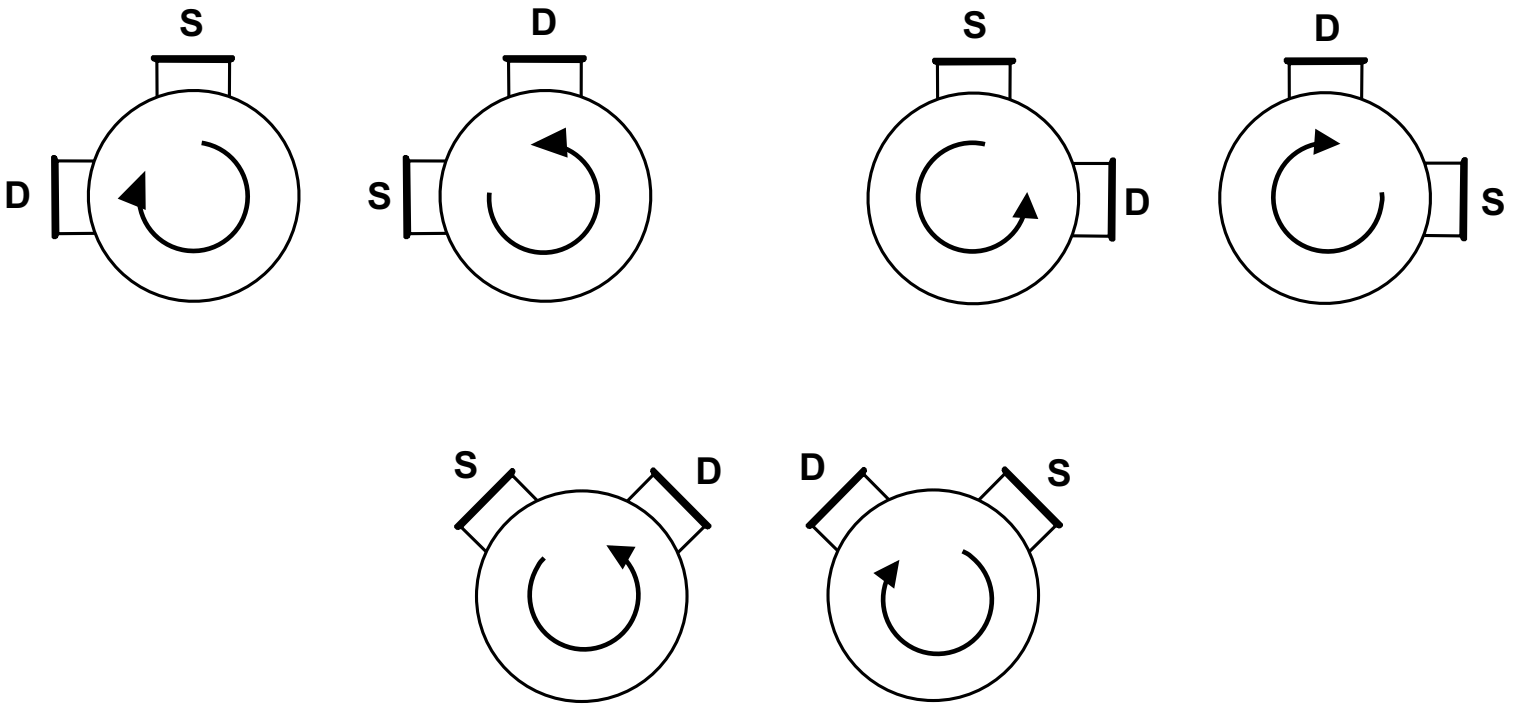

Figure 1 - Front Views

3. Rotate the pump housing such that the nozzles are in a desired position. Holes have already been drilled in the rear of the pump housing to facilitate any position of the nozzles.
4. Place the pump housing back onto the power frame being sure to align the bolt holes of both parts. Install the housing mounting washers and bolts and tighten to the torque specification on page 28. **NOTE: Failure to tighten the bolts to the specification may cause damage to the wet end parts, as the rotor will not be centered in the housing properly.**
5. Replace the parts in the wet end of the pump. Refer to the Wet End Assembly section of this manual. Be sure to install the scrapergate and scrapergate guide in the correct position. Refer to page 20.



Bearing Oil Lubrication Recommendations

There are three plugs located in the bearing housing as shown in Figure 1 below. To determine if the bearings are properly lubricated, remove the level plug. If oil is not visible, remove the fill plug and fill the bearing housing until oil is visible through the level plug hole. Replace both plugs.

For proper lubrication and maintenance, use the following guidelines:

1. Use **Lubriplate FMO 2400 AW gear oil** or equivalent food grade oil in the bearing housing.
2. Check the oil level weekly. Be sure that all plugs are fully tightened when installing to prevent water or other foreign matter from entering the bearing housing.
3. Change the oil every 5000 hours of operation for ambient temperature pumpage. Change the oil every 2000 hours of operation for pumpage above 150°F.
4. Fill the bearing housing with oil only to the level hole, as overfilling may cause the bearings to fail prematurely.

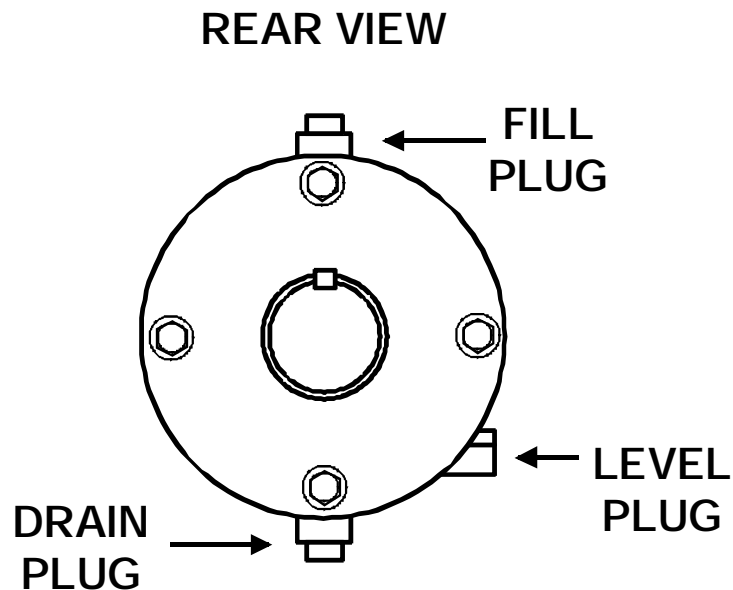

Figure 1

Assembly Instructions for Installation of Front Cover Hinge

The front cover hinge is available for the MR-135 and the MR-150 Sine Pump. It allows for the front cover to be hinged to the pump housing for easier maintenance. When assembling the front cover hinge, follow the steps below and refer to Figure 1 and the associated parts list. Install the hinge only when the front cover is attached to the pump housing.

1. Attach the ring arm, item 1a or 1b, to the top nozzle of the pump and insert the two cap screws, item 3, into the slots on the diameter of the ring. Do not tighten the cap screws completely. NOTE: The ring arm is two pieces, a half ring and a half ring with a rectangular bar welded to it. The ring arm can point to either side of the pump depending on which way you prefer the front cover to swing away from the pump housing.
2. Stack the following items, with their holes aligned, above the hole at the end of the ring arm in the order listed: a.) one plastic washer, item 4, b.) the pivot arm, item 2, using the smaller diameter hole c.) the other plastic washer, item 4, and d.) the stainless steel washer, item 5. Install the bolt, item 5, by fitting it through the stacked items and threading it into the hole on the right arm. Tighten the bolt until the parts are secure but loose enough to allow rotation of the pivot arm. Thread the hex nut, item 7, onto the bolt and tighten securely to lock the bolt in place.
3. Attach the rod end, item 8, with two washers, item 11, on either side of the ball, to the front cover using the bolt, item 10. The bolt will thread into the tapped hole on the front cover.
4. Place the washer, item 11, on the bolt, item 9, and insert the bolt through the hole on the end of the pivot arm. Thread the hex nut, item 12, onto the end of the bolt, but do not tighten.
5. With the rod end held upwards toward the pivot arm, thread the bolt into the hole in the rod end.
6. Rotate the ring arm until the rod end is vertical as shown in Figure 1. Tighten the cap screws until the ring arm is secure.
7. Tighten the bolt which connects the pivot arm to the rod end until the head comes into contact with the washer.
8. Remove the wing nuts and front cover. By either tightening or loosening the hex nut on top of the rod end or adjusting the alignment of the ring arm, the height of the front cover when hanging can be modified to ease assembly.

Two holes have been drilled and tapped in the face of the front cover to house the bolt which holds the front cover onto the hinge assembly. One of the holes will not be used depending on the location of the hinge assembly and the orientation of the inlet and outlet nozzles. This hole can be fitted with a 3/8 - 16 x 1/2" bolt.

If the hinge is purchased as a spare part, please contact Sine Pump Technical Services at 303-425-0800 for the required modification drawing necessary to locate the holes in the front cover.

Assembly Instructions for Installation of Front Cover Hinge, cont.

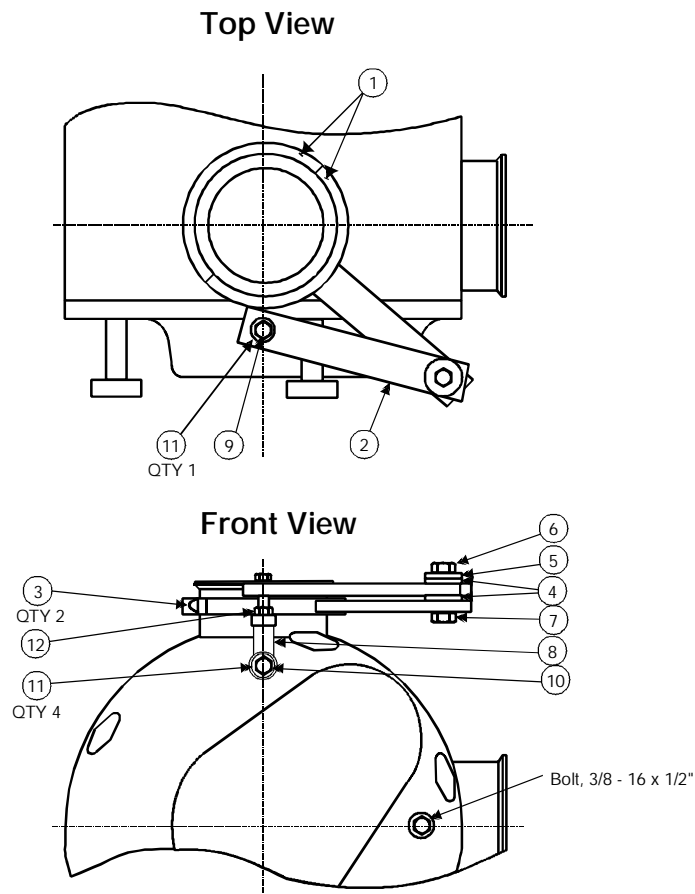

Figure 1

Item	Description	Part Number	Qty
1a*	Ring Arm (MR-150)	050P460.1304A1	1
1b*	Ring Arm (MR-135)	035P460.1304A1	1
2	Pivot Arm	035P461.1304A1	1
3	Cap Screw	035P426.1300A1	2
4	Washer, Plastic, 3/8	035P463.2636A1	2
5	Washer, SS, 3/8	035P463.1304A1	1
6	Bolt, 3/8-16 x 1-3/4	035P464.1300A1	1
7	Hex Nut, 3/8 – 16	035P465.1300A1	1
8	Rod End, Female	035P466.1303A1	1
9	Bolt, 3/8-24 x 1-1/4	035P467.1300A1	1
10	Bolt, 3/8-16 x 1-1/4	035P468.1300A1	1
11	Washer, 3/8	035P469.1300A1	5
12	Hex Nut, 3/8 – 24	035P470.1300A1	1

*For the MR-150, use item 1 a; for the MR-135, use item 1 b.

How to use the Removal Tools

Removal tools are supplied with every new Sine Pump. The tools are shaped like skate blades and have a pin extending from one end (see Figure 1). These tools are used for removing the rear liner and the seal housing

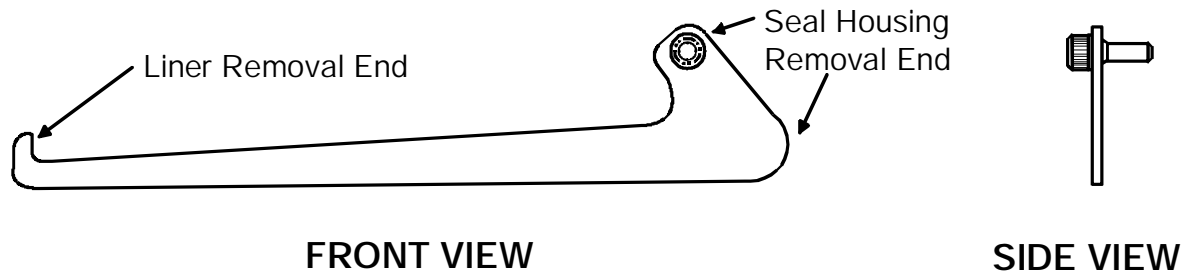

Figure 1

To use the tool remove the seal housing from the pump, simply insert the pin at the end of the tool into the hole on the outer diameter of the seal housing (see Figure 2). Two holes have been drilled in the seal housing, 180° apart, to facilitate the use of both tools. By applying downward pressure to the hooked ends of the tools, the seal housing will be pulled from the rear of the pump housing. Always use both tools when removing the seal housing to prevent it from wedging in the pump housing.

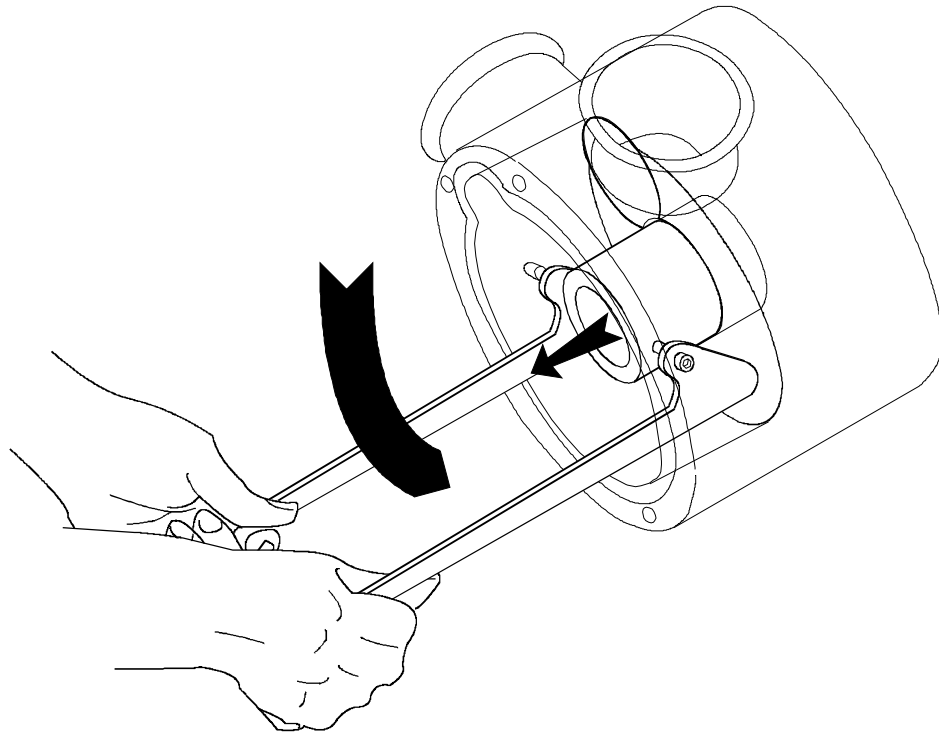

Figure 2

How to use the Removal Tools

To use the tool to remove the rear liner from the pump housing, simply insert the hooked ends of the tools into the slotted ends of the liner and pull forward (See Figure 3). Pull on both tools with even pressure when removing the liner to prevent the liner from wedging in the pump housing.

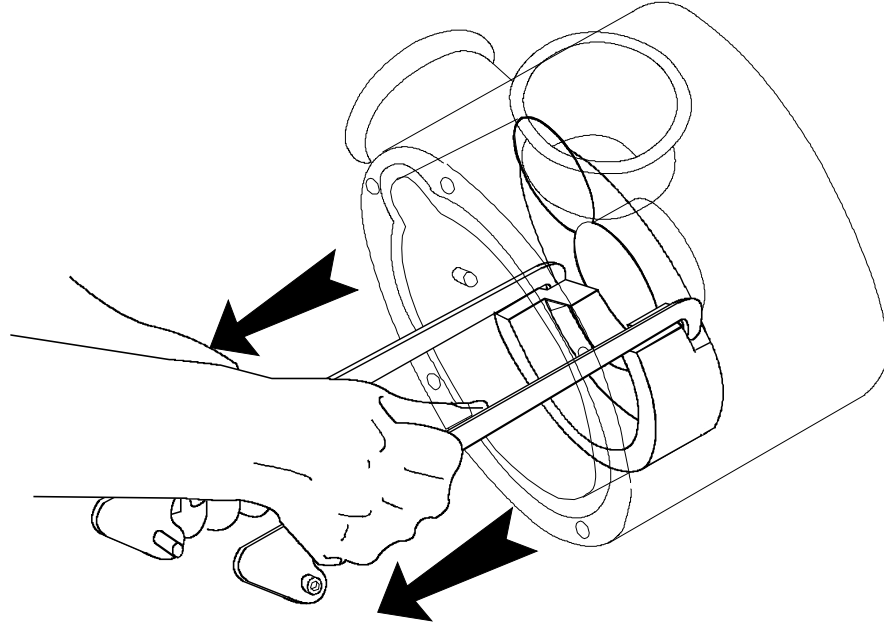

Figure 3

Torque Specifications

Pump Model	Rotor Nut		Housing Mounting Bolt		Bearing Housing Mounting Cap Screw		Bearing Housing Cover Cap Screw		Wing Nut	
	ft•lbs	N•m	ft•lbs	N•m	ft•lbs	N•m	ft•lbs	N•m	ft•lbs	N•m
MR-120	40	54	18	24	14	19	4	5	14	19
MR-125	60	81	18	24	14	19	4	5	14	19
MR-130	60	81	18	24	18	24	8	11	18	24
MR-135 MR-135RF	80	108	18	24	18	24	8	11	18	24
MR-150 MR-150RF	100	135	18	24	25	34	14	19	25	34

Sine Pump Weights

Pump Model	Pump Only	Pump w/Box & Skid
MR-120	68 lbs. 31 kg.	74 lbs. 34 kg.
MR-125	125 lbs. 57 kg.	145 lbs. 66 kg.
MR-130	240 lbs. 109 kg.	265 lbs. 121 kg.
MR-135/MR-135RF	270 lbs. 123 kg.	295 lbs. 134 kg.
MR-150/MR-150RF	460 lbs. 209 kg.	475 lbs. 216 kg.

Troubleshooting the Sine Pump

Problem	Possible Causes	Remedy
Inadequate Flow	<ol style="list-style-type: none"> 1. Incorrect shaft rotation 2. Scrapergate installation 3. Air leaks – external, internal (loose fittings, lip seals) 	<ol style="list-style-type: none"> 1. (A) Check rotation (B) Change wiring 2. Change Scrapergate & Guide 3. (A) Tighten fittings , i.e. Tri Clamp (B) Replace worn lip seals or o-rings
Loss of Performance	<ol style="list-style-type: none"> 1. Worn Scrapergate 2. Scrapergate support or seal housing worn where scrapergate shuttles 3. Worn Liners 	<ol style="list-style-type: none"> 1. Check for wear & replace 2. Rotate to get a clean spot 3. Replace if worn
Leaks	<ol style="list-style-type: none"> 1. O-rings (pinched, cut, missing) 2. Lip seals or seal housing damages 3. Grooves in shaft sleeve from abrasive applications or high discharge pressure 	<ol style="list-style-type: none"> 1. Visual inspection – replace 2. Rebuilt or replace assembly 3A. Check system for discharge pressure problems 3B. Consider hard coating shaft sleeve
Accelerated Wear	<ol style="list-style-type: none"> 1. Speed or abrasion 2. Excessive discharge pressure (>150 PSIG) 3. Dry Run 	<ol style="list-style-type: none"> 1. (A) Decrease pump speed (B) Use larger pump 2. (A) Increase line size (B) Check valves (C) Check viscosity & line losses 3. (A) Recommend level control (B) Change internals

Product Line

SINE PUMP SPECIFICATIONS					
Model	Displacement (Gallons/Revolutions) (CC/Revolutions)	Inlet/Outlet (Inches) (MM)	Max. Particle Size (Inches) (MM)	Max. Capacity (GPM) (L/H)	Max. Speed (RPM)
SPS-1 (2)	.015	1x1	3/16	15	1000
	53	25x25	4.7	3,400	
MR-120	.03	2x2	1/4	24	800
	106	50x50	6.5	5,450	
MR-125	.06	2 1/2x2 2/2	1/2	48	800
	224	63.5x63.5	12.5	10,900	
MR-130	.124	3x3	3/4	99	800
	470	75x75	19	22,485	
MR-135	.23	3x3	1 1/4	138	600
	875	75x75	31	31,343	
MR-135RF	.23	(2 1/2x9 1/4*)x3	1 1/4	138	600
	875	(34x235*)x75	31	31,343	
MR-150	.47	4x4	2	282	600
	1,784	100x100	50	64,049	
MR-150RF*	.47	(3 1/2x11*)x4	2	282	600
	1,784	(90x280*)x100	50	64,049	
SPS-6 (2)	.67	6x6	2 1/2	402	600
	2,544	152x152	63	91,304	

RF models incorporate rectangular flanges on the suction side and bevel seat nozzles on the discharge side.

NOTE:

1. This is a guideline only, consult the factory when approaching maximum values for particulate size, capacity or pump speed.
2. The SPS-1 and SPS-6 are not covered by this manual.

SINE PUMP

SOFTWARE MATERIAL GUIDE

Software Material	Description	Color	Advantages	Disadvantages	Max. Ratings
-------------------	-------------	-------	------------	---------------	--------------

LINERS

PBT	Polybutylene Terephthalate	White	Good Performance Low Cost	High Temperature Abrasives	190° F 150 psi
PPS	Polyphenylsulfid	Blue	High Temperature Good Performance Chemical Resistance SPS-1 / SPS-6	Severe Abrasives	250° F 225 psi
Polyamid	Polyamide	Off White	For use with SPS-1 / SPS-6	High Temperature Severe Abrasives	200° F 150 psi
HTP	Reinforced Polyetherimide	Off White	Good Performance High Temperature	Severe Abrasives	300° F 150 psi
Stainless Steel	Stainless Steel	Silver	High Temperature Abrasives	Higher Cost	300° F 225 psi

SCRAPERGATES

UHMW	Ultra High Molecular Weight Polyethylene	White	Low Cost	High Temperature High Pressure	150° F 100 psi
Peek	Polyetheretherketon	Black	High Temperature Chemical Resistance SPS-1 / SPS-6	Higher Cost	275° F 225 psi
Polyamid	Polyamide	Off White	For use with SPS-1 / SPS-6	High Temperature Severe Abrasives	200° F 225 psi
Sinar	Reinforced Nylon	Yellow	High Temperature Abrasives	Higher Cost	300° F 150 psi

Effective Jan 1, 2000
Supersedes Jan 1, 1999

Pg. 1 of 2

SHAFT SLEEVES

316 SS	Stainless Steel	Silver	High Temperature Low Cost	Abrasives	300° F 150 psi
Hard Coated	Ceramic Oxide Coated Stainless	Black	Abrasives High Pressure	Higher Cost	300° F 150 psi

NOTE: The dynamic radial o-ring seal assembly requires the hard coated shaft sleeve.

LIP SEALS & O-RINGS

Buna	Elastomer	Black	Abrasives Low Cost	High Temperature	200° F 150 psi
Viton	Elastomer	Brown	High Temperature Chemical Resistance	Severe Abrasives Higher Cost	300° F 150 psi
EPDM	Elastomer	Black	Chemical Resistance	Higher Cost	300° F 150 psi

NOTE: EPDM material is not available for the dynamic radial or dynamic face o-rings.

Effective Jan 1, 2000
Supersedes Jan 1, 1999

Pg. 2 of 2

Seal Options

1. Lip Seal Assembly

This is the standard seal which is used in the Sine Pump. It consists of three lip seals, two of which are used to seal product into the pump, and one which is used to prevent the pump from pulling air. The two front lip seals incorporate a stainless steel support ring enabling the assembly to withstand pressures from the product side up to 150 psi. Figure 1 shows a list of parts and an accompanying cross section drawing which makes up the lip seal assembly

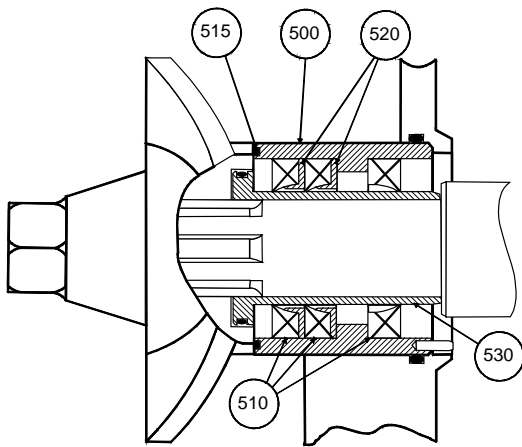

Item	Description
500	Lip Seal Housing
510	Lip Seal (3)
515	Dynamic Face O-Ring
520	Support Ring (2)
530	Lip Seal Shaft Sleeve

Figure 1

2. O-Ring Seal Assembly

The o-ring seal assembly uses a single elastomeric o-ring to seal the product from escaping the pump housing. This type of seal arrangement can be used only when product pressures do not exceed 100 psi and the shaft speed does not exceed 300 rpm. Figure 2 shows a list of parts and an accompanying cross section drawing which makes up the o-ring seal assembly.

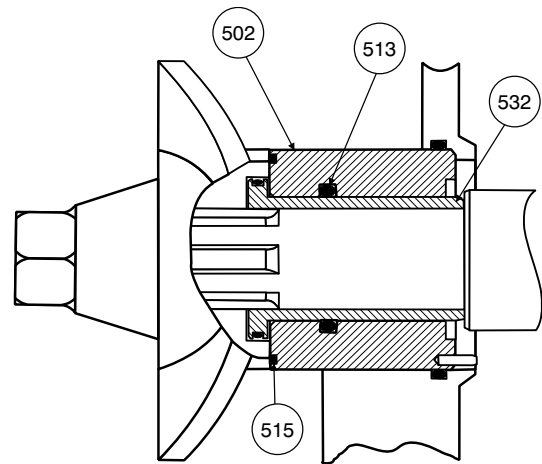

Item	Description
502	O-Ring Seal Housing
513	Dynamic Radial O-Ring
515	Dynamic Face O-Ring
532	O-Ring Seal Shaft Sleeve

Figure 2

Seal Options

3. Single Mechanical Seal Assembly

The Sine Pump mechanical seal arrangement consists of a John Crane Type 9 seal. This uses a stationary ceramic face in contact with a rotating carbon face to achieve the sealing and is rated to product pressures up to 150 psi. Figure 3 shows a list of parts and an accompanying cross section drawing which makes up the mechanical seal assembly.

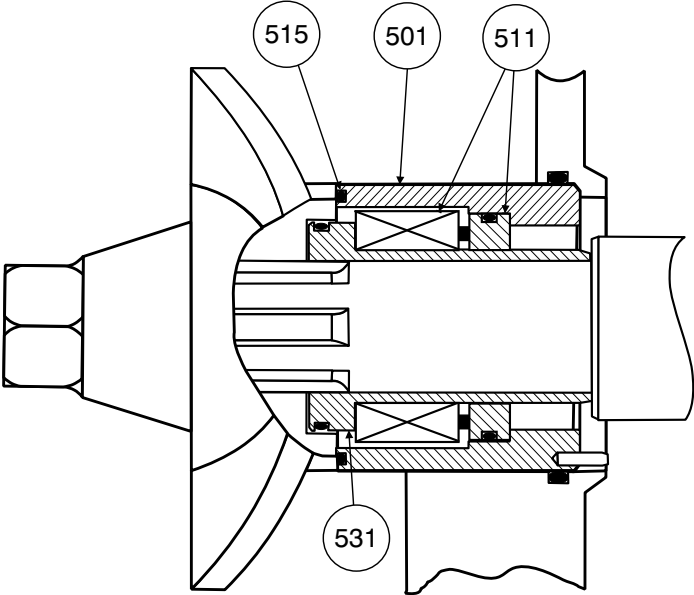

Item	Description
501	Mechanical Seal Housing
511	John Crane Mechanical Seal
515	Dynamic Face O-Ring
531	Mechanical Seal Shaft Sleeve

Figure 3

Seal Options

4. Double Lip Seal with Flush

This seal arrangement uses two lip seals and a flush media to seal product into the Sine Pump. Both lip seals incorporate a stainless steel support ring and snap ring enabling the assembly to withstand product and flush pressures up to 150 psi. Figure 1 shows a list of parts and an accompanying cross section drawing which makes up the double lip seal with flush assembly.

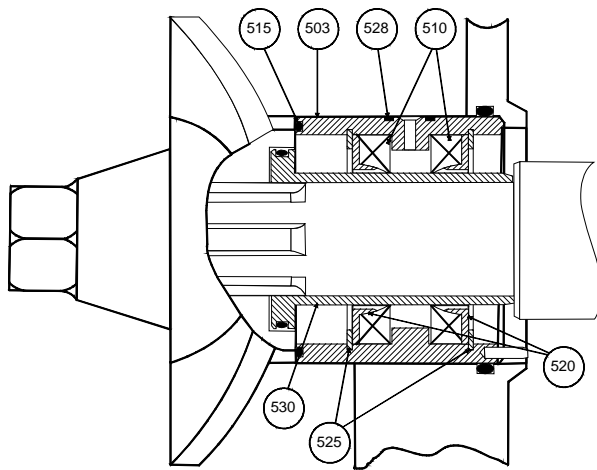

Figure 4

5. Double O-Ring Seal with Flush

This seal arrangement uses two o-rings and a flush media to seal product into the Sine Pump. This type of seal can be used only when product and flush pressures do not exceed 100 psi and the shaft speed does not exceed 3000 rpm. Figure 2 shows a list of parts and an accompanying cross section drawing which makes up the o-ring seal assembly.

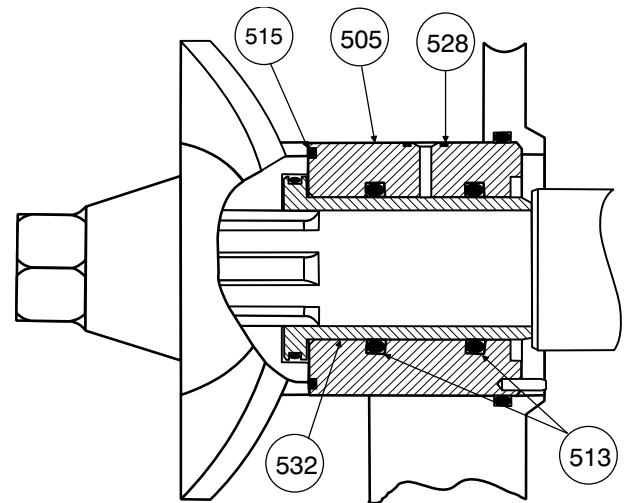

Figure 5

Item	Description
503	Double Lip Seal with Flush Housing
510	Lip Seal (2)
515	Dynamic Face O-Ring
520	Support Ring (2)
525	Snap Ring (2)
528	Seal Flush O-Ring (2)
530	Lip Seal Shaft Sleeve

Item	Description
505	Double O-Ring Seal with Flush Housing
513	Dynamic Radial O-Ring (2)
515	Dynamic Face O-Ring
528	Seal Flush O-Ring (2)
532	O-Ring Seal Shaft Sleeve

Cross Section and Parts

MR-120
MR-125
MR-130

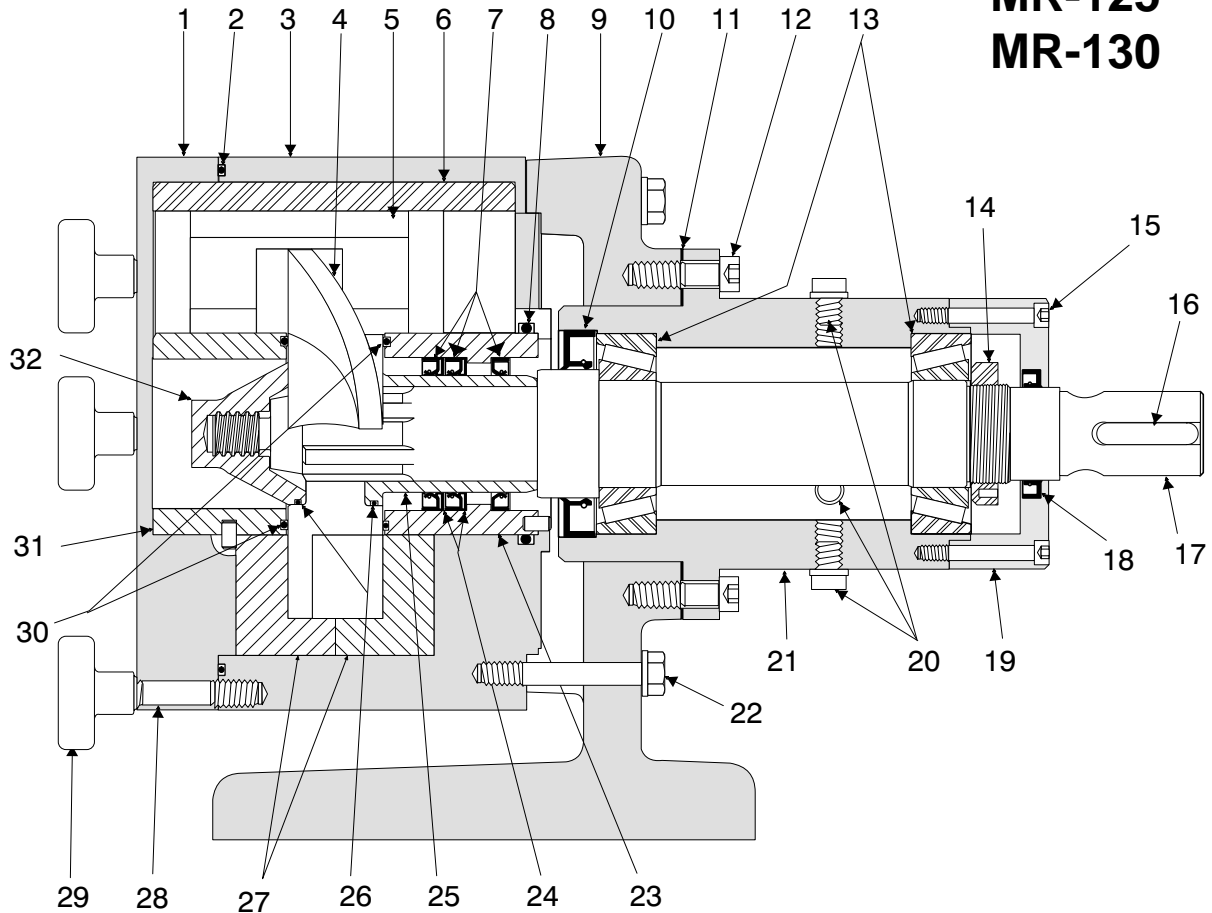

No.	Item	Description	No.	Item	Description	No.	Item	Description
1	400	Front Cover	12	640	Power Frame Cap Screw	23	500	Seal Housing
2	430	Front Cover O-Ring	13	770	Tapered Roller Bearings	24	520	Lip Seal Support Rings
3	300	Pump Housing	14	750	Bearing Lock Nut	25	530	Shaft Sleeve
4	011	Rotor	15	768	Bearing Housing Cap Screw	26	030	Rotor O-Rings
5	125	Scrapergate	16	250	Shaft Key	27	072	Liners
6	100	Scrapergate Guide	17	200	Shaft	28	450	Front Cover Stud
7	510	Lip Seals	18	742	Oil Seal, Outboard	29	441	Front Cover Wing Nut
8	540	Seal Housing O-Ring	19	761	Bearing Housing Cover	30	515	Dynamic Face O-Rings
9	600	Power Frame	20	737	Oil Level/Fill/Drain Plugs	31	370	Scrapergate Support
10	741	Oil Seal, Inboard	21	700	Bearing Housing	32	231	Shaft Nut
11	800	Shims	22	340	Housing Mounting Bolt			

Wet End Exploded View

MR-120 MR-125 MR-130

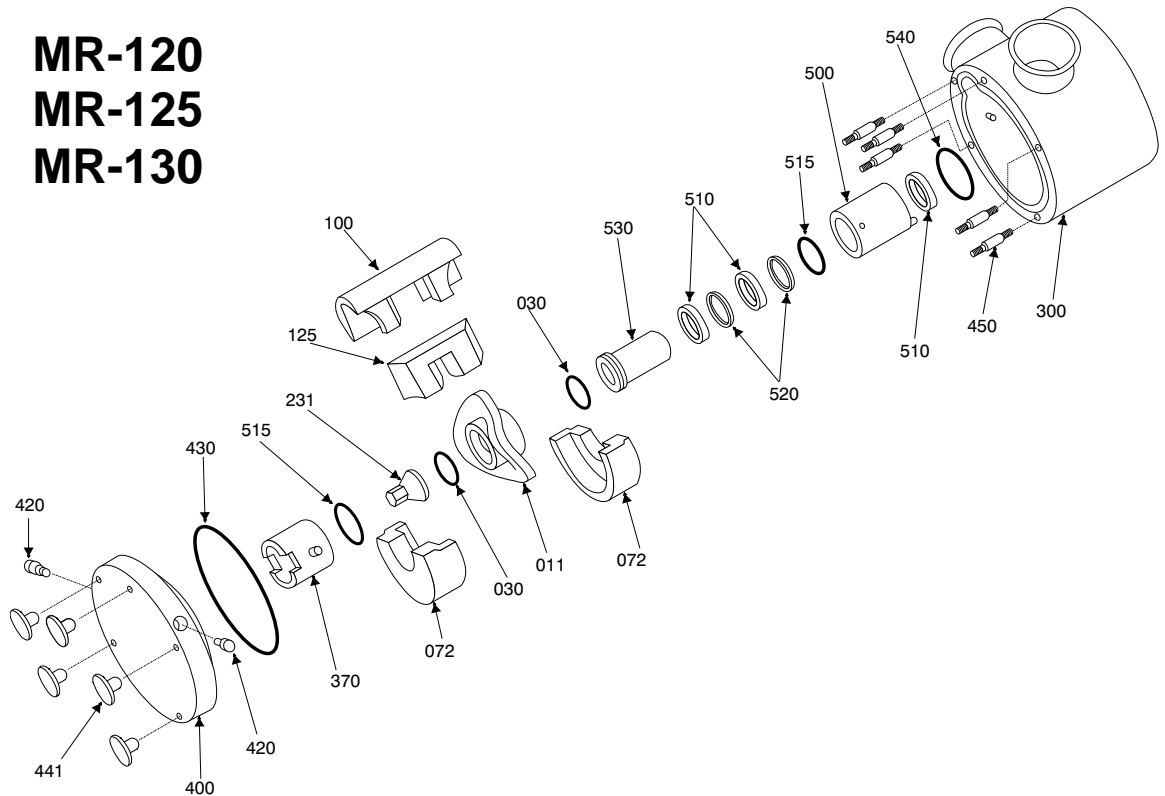

NOTES;

1. Orientation of the scrapergate, item 125, and the scrapergate guide, item 100 will vary depending on application suction conditions. For details, refer to page 20.
2. Pump housings, item 300, are available with nozzle and jacketing options
3. Front covers, item 400, are available with optional jacketing.
4. Dynamic face o-rings, item 515, are only required with stainless steel scrapergate supports, item 370, and seal housings, item 500.
5. Seal options include the triple lip seal (shown above), the o-ring seal, and the mechanical seal. Double seal with flush options include the lip seal and o-ring seal. For details, refer to pages 33-35.

Item No.	Description	Item No.	Description
011	Rotor	430	Front Cover O-Ring
030	Rotor O-Rings	441	Front Cover Wing Nut
072	Liners	450	Front Cover Stud
100	Scrapergate Guide	500	Seal Housing
125	Scrapergate	510	Lip Seals
231	Shaft Nut	515	Dynamic Face O-Ring
300	Pump Housing	520	Lip Seal Support Rings
370	Scrapergate Support	530	Shaft Sleeve
400	Front Cover	540	Seal Housing O-Ring
420	Front Cover Pin		

Power End Exploded View

**MR-120
MR-125
MR-130**

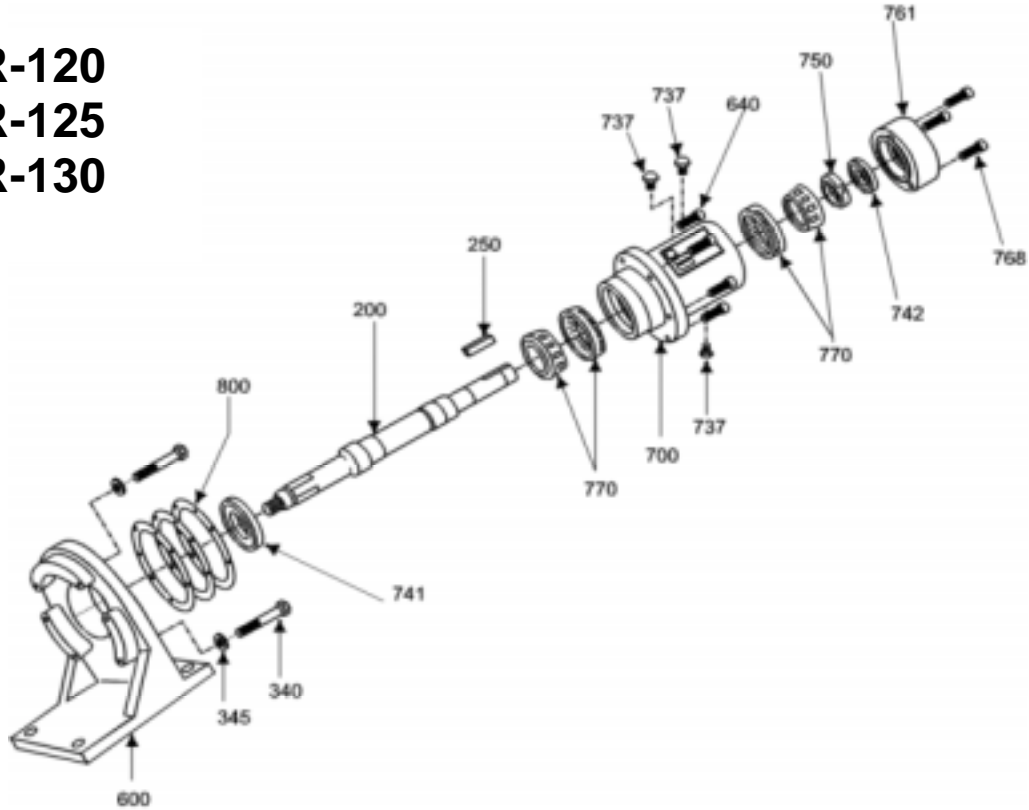

Note: Shims (Item 800) may vary in both number and thickness.

Item No.	Description	Item No.	Description
200	Shaft	741	Oil Seal, Inboard
250	Shaft Key	742	Oil Seal, Outboard
340	Housing Mounting Bolts	750	Baring Lock Nut
345	Housing Mounting Washers	761	Bearing Housing Cover
600	Power Frame	768	Bearing Housing Cover Cap Screws
640	Bearing Housing Mounting Cap Screws	770	Tapered Roller Bearings
700	Bearing Housing	800	Shims
737	Oil Fill/Level/Drain Plugs		

Dimensions – Inches (Millimeters)

**MODEL
MR-120**

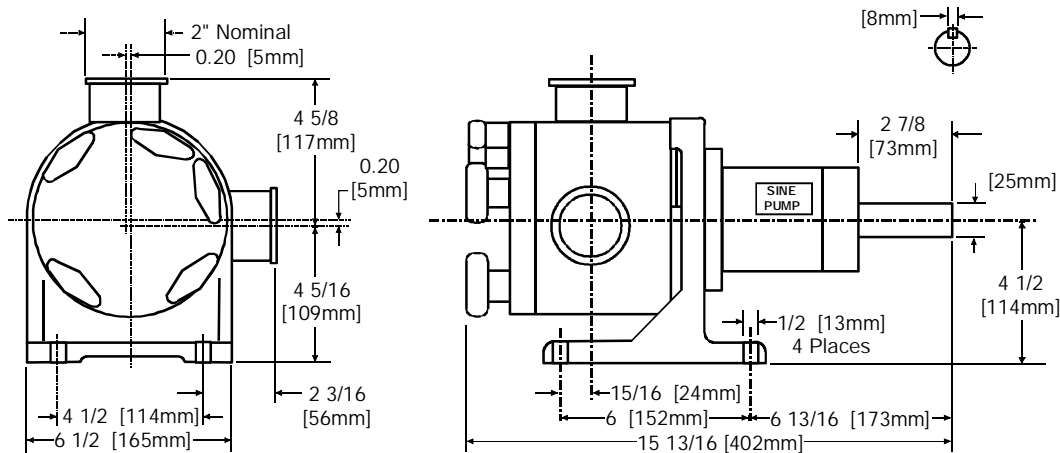

**MODEL
MR-125**

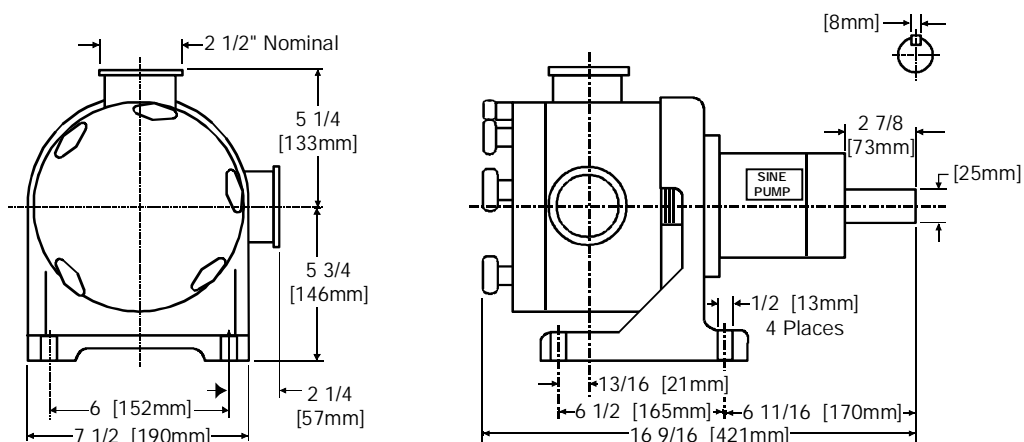

**MODEL
MR-130**

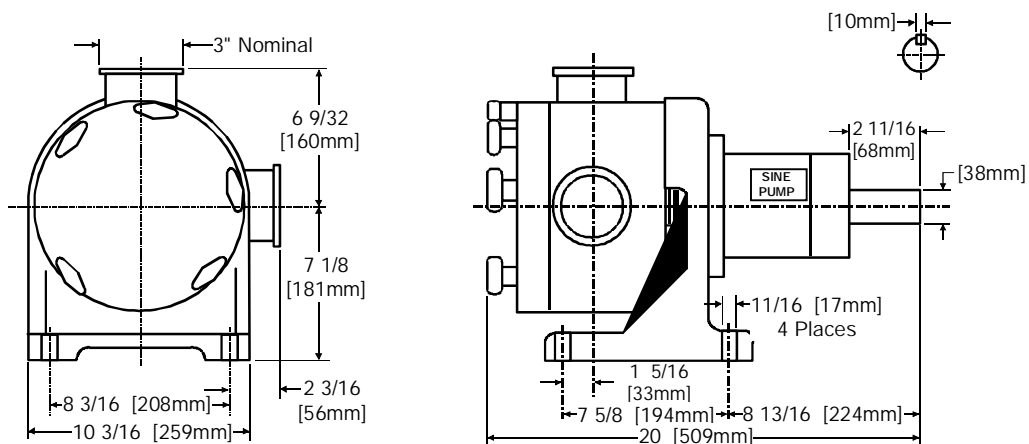

TOLERANCE ON DIMENSIONS: $\pm 1/16$ (± 1.5 MM)
FOR REFERENCE ONLY - NOT FOR CONSTRUCTION UNLESS CERTIFIED.

Cross Section and Parts

MR-135
MR-150

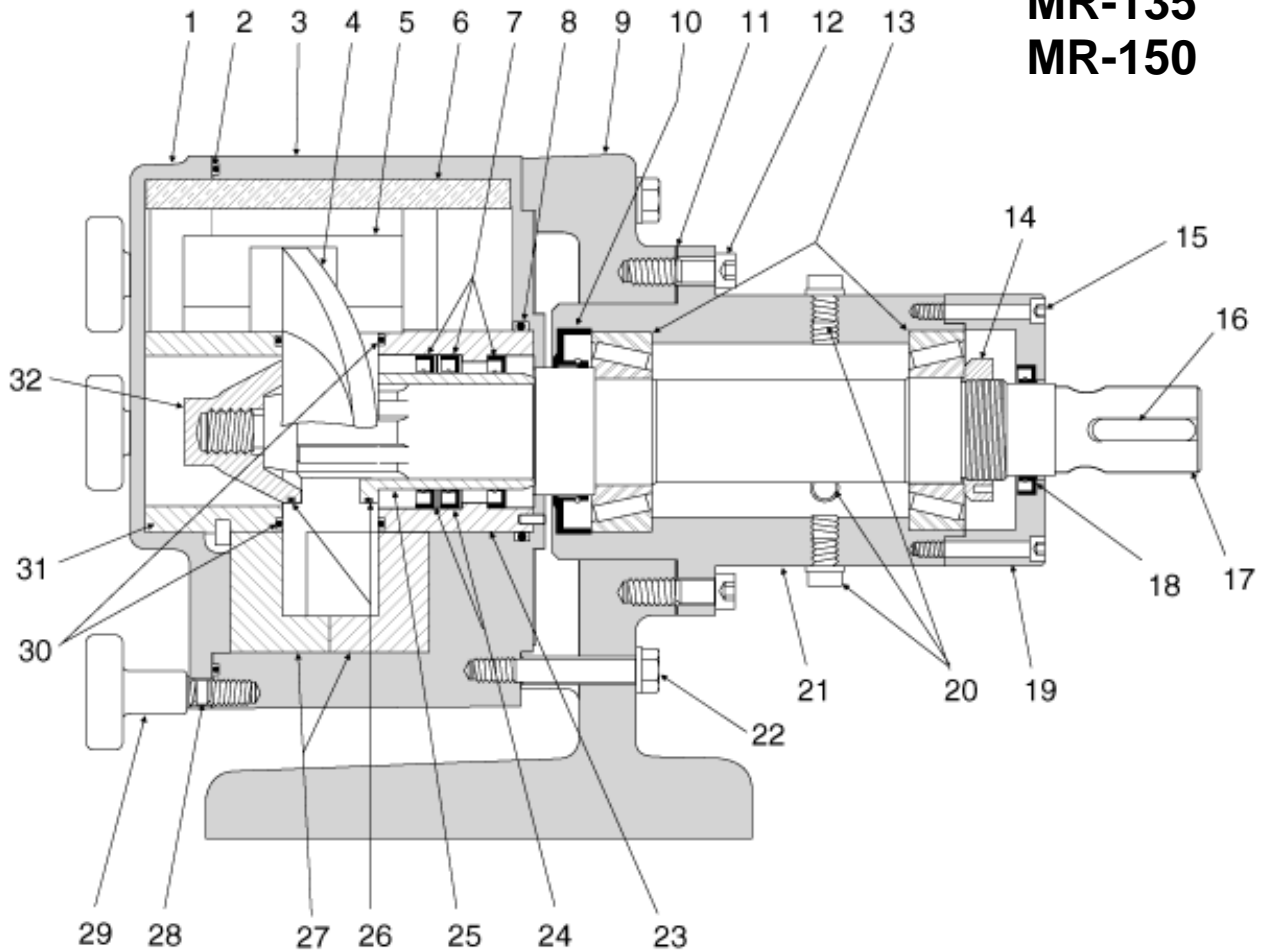

No.	Item	Description	No.	Item	Description	No.	Item	Description
1	400	Front Cover	12	640	Power Frame Cap Screw	23	500	Seal Housing
2	430	Front Cover O-Ring	13	770	Tapered Roller Bearings	24	520	Lip Seal Support Rings
3	300	Pump Housing	14	750	Bearing Lock Nut	25	530	Shaft Sleeve
4	011	Rotor	15	768	Bearing Housing Cap Screw	26	030	Rotor O-Rings
5	125	Scrapergate	16	250	Shaft Key	27	072	Liners
6	100	Scrapergate Guide	17	200	Shaft	28	450	Front Cover Stud
7	510	Lip Seals	18	742	Oil Seal Outboard	29	441	Front Cover Wing Nut
8	540	Seal Housing O-Ring	19	761	Bearing Housing Cover	30	515	Dynamic Face O-Ring
9	600	Power Frame	20	737	Oil Level/Fill/Drain Plugs	31	370	Scrapergate Support
10	741	Oil Seal, Inboard	21	700	Bearing Housing	32	231	Shaft Nut
11	800	Shims	22	340	Housing Mounting Bolt			

Wet End Exploded View

MR-135 MR-150

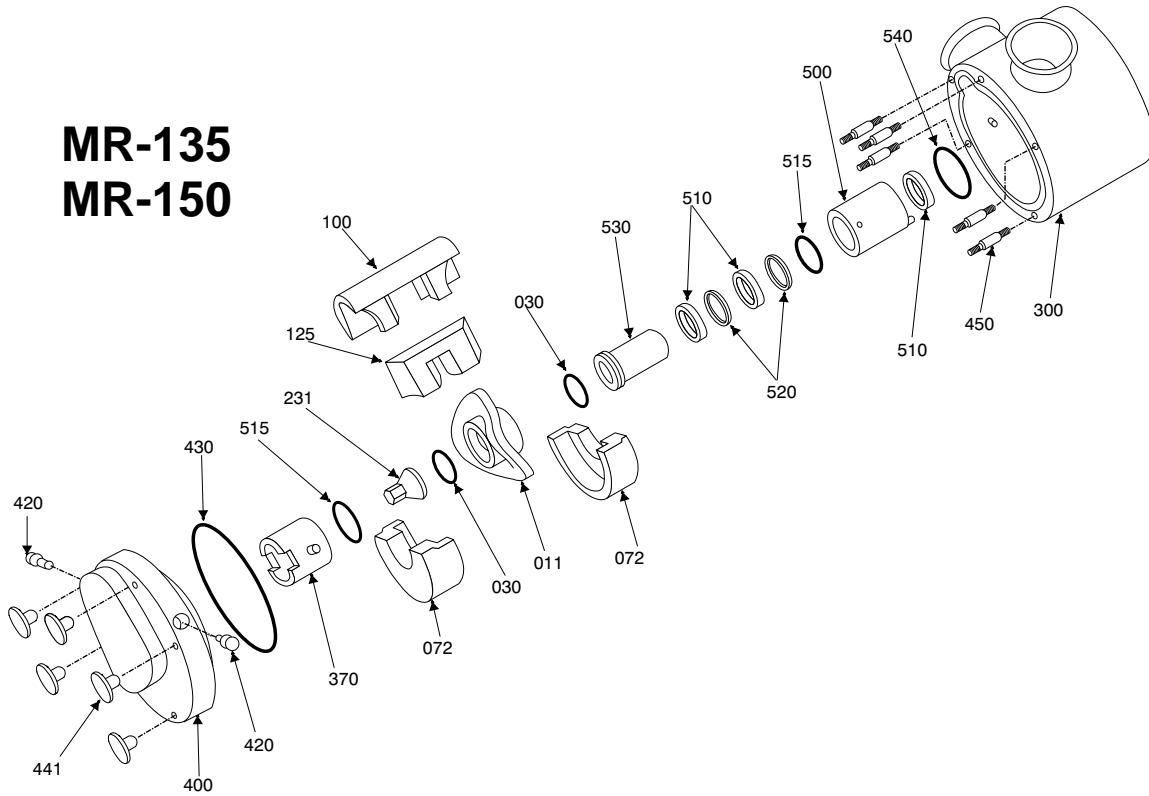

Notes

1. Orientation of the scraper gate, item 125, and the scraper gate guide, item 100, will vary depending on application suction conditions. For details, refer to page 20.
2. Pump housings, item 300, are available with nozzle and jacketing options.
3. Front covers, item 400, are available with optional jacketing.
4. Dynamic face o-rings, item 515, are only required with stainless steel scraper gate supports, item 370, and seal housings, item 500.
5. Seal options include the triple lip seal (shown above), the o-ring seal, and the mechanical seal. Double seal with flush options include the lip seal and o-ring seal. For details, refer to pages 33-35.

Item No.	Description	Item No.	Description
011	Rotor	430	Front Cover O-Ring
030	Rotor O-Rings	441	Front Cover Wing Nut
072	Liners	450	Front Cover Stud
100	Scraper Gate Guide	500	Seal Housing
125	Scraper Gate	510	Lip Seals
231	Shaft Nut	515	Dynamic Face O-Rings
300	Pump Housing	520	Lip Seal Support Rings
370	Scraper Gate Support	530	Shaft Sleeve
400	Front Cover	540	Seal Housing O-Ring
420	Front Cover Pin		

Power End Exploded View

**MR-135
MR-150**

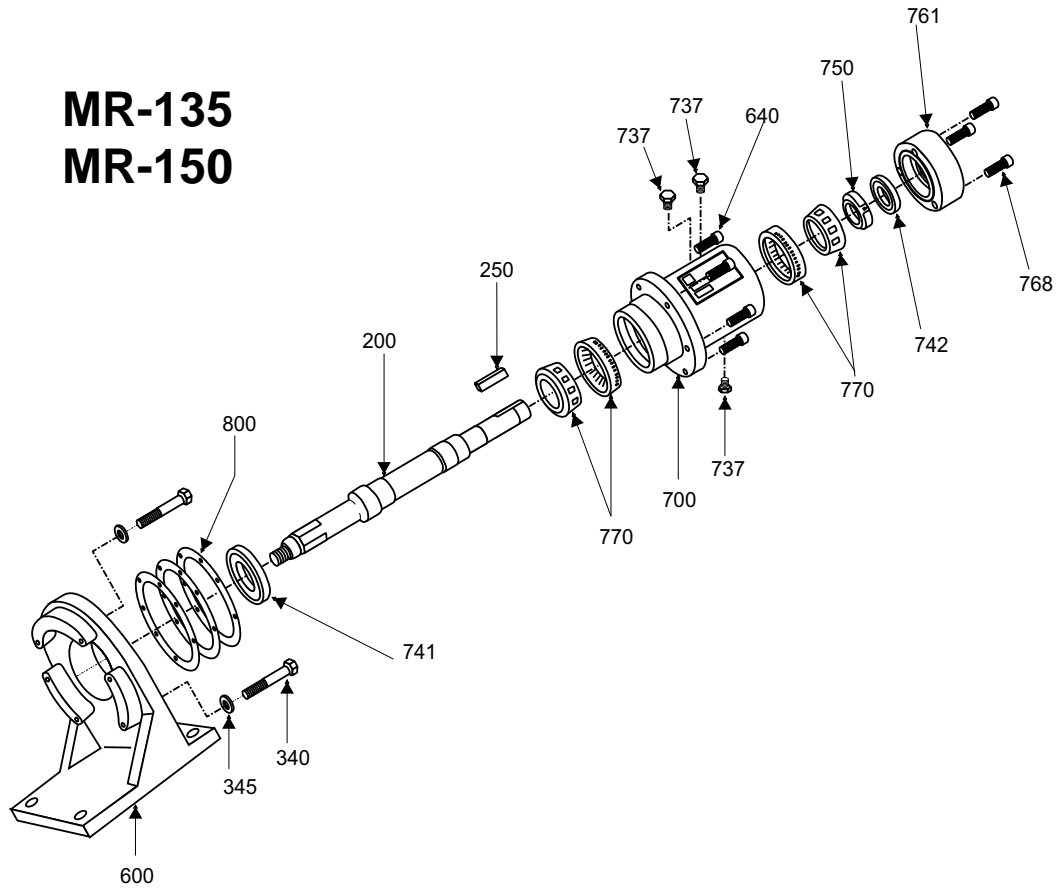

Notes:

1. Shims (Item 800) may vary in both number and thickness.
2. Inboard tapered roller bearing, item 770, on the MR-150 is larger than the outboard tapered roller bearing.

Item No.	Description	Item No.	Descriptions
200	Shaft	741	Oil Seal, Inboard
250	Shaft Key	742	Oil Seal, Outboard
340	Housing Mounting Bolts	750	Bearing Lock Nut
345	Housing Mounting Washers	761	Bearing Housing Cover
600	Power Frame	768	Bearing Housing Cover Cap Screw
640	Bearing Housing Mounting Cap Screws	770	Tapered Roller Bearings
700	Bearing Housing	800	Shims
737	Oil Fill/Level/Drain Plugs		

Dimensions – Inches (Millimeters)

MR-135

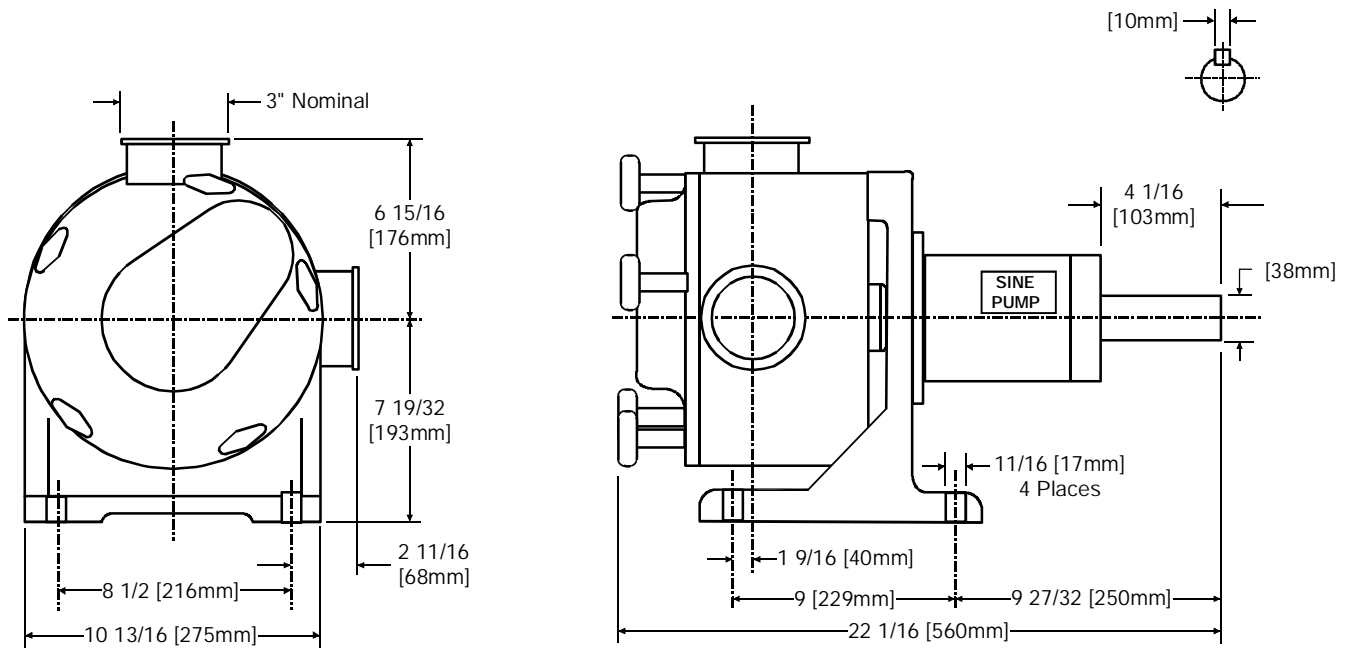

MR-150

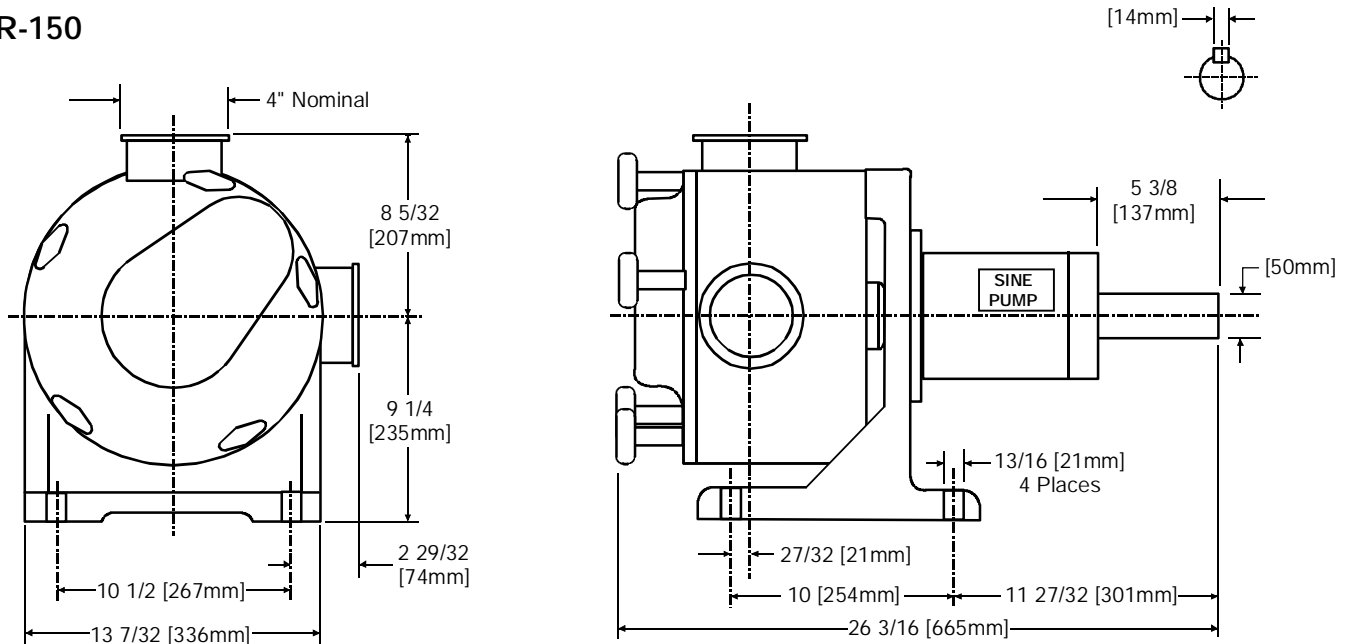

TOLERANCE ON DIMENSIONS: $\pm 1/16$ (± 1.5 MM)
 FOR REFERENCE ONLY - NOT FOR CONSTRUCTION UNLESS CERTIFIED.

Cross Section and Parts

MR-135RF
MR-150RF

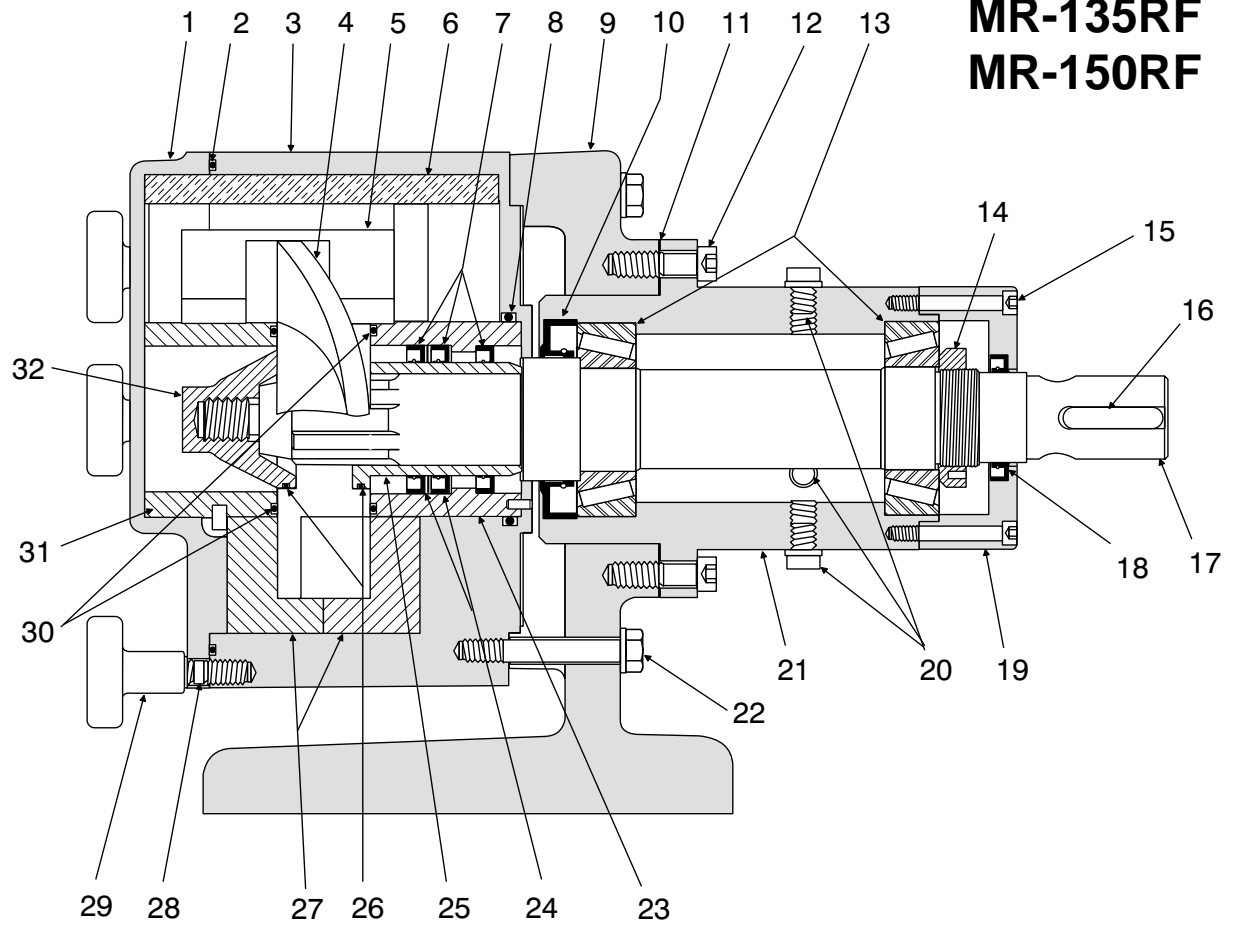

No.	Item	Description	No.	Item	Description	No.	Item	Description
1	405	Front Cover	12	640	Power Frame Cap Screw	23	500	Seal Housing
2	430	Front Cover O-Ring	13	770	Tapered Roller Bearings	24	520	Lip Seal Support Rings
3	305	Pump Housing	14	750	Bearing Lock Nut	25	530	Shaft Sleeve
4	011	Rotor	15	768	Bearing Housing Cap Screw	26	030	Rotor O-Rings
5	125	Scrapergate	16	250	Shaft Key	27	073	Liners
6	100	Scrapergate Guide	17	200	Shaft	28	450	Front Cover Stud
7	510	Lip Seals	18	742	Oil Seal Outboard	29	441	Front Cover Wing Nut
8	540	Seal Housing O-Ring	19	761	Bearing Housing Cover	30	515	Dynamic Face O-Rings
9	600	Power Frame	20	737	Oil Level/Fill/Drain Plugs	31	370	Scrapergate Support
10	741	Oil Seal, Inboard	21	700	Bearing Housing	32	231	Shaft Nut
11	800	Shims	22	340	Housing Mounting Bolt			

MR-135RF MR-150RF

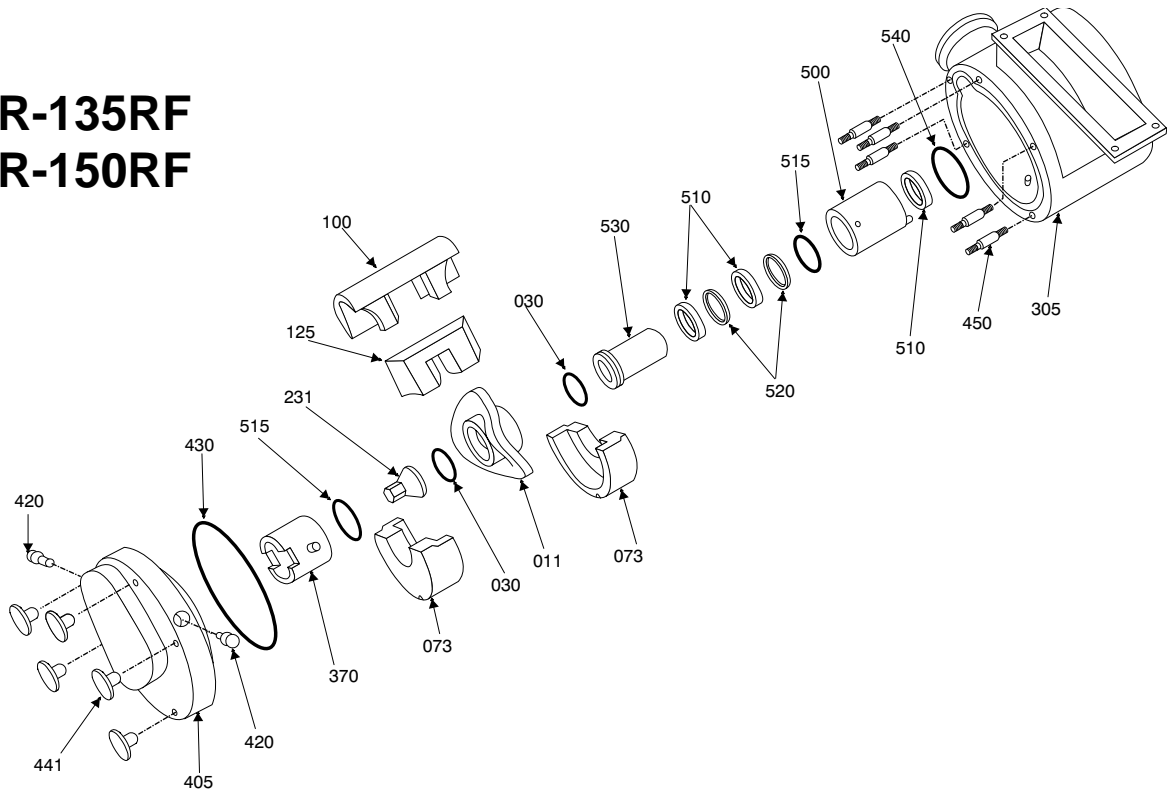

Notes

1. Orientation of the scrapergate, item 125, and the scrapergate guide, item 100, will follow the suction right or "SR" condition. For details, refer to page 20.
2. Pump housings, item 305, are available with nozzle and jacketing options.
3. Front covers, item 405, are available with optional jacketing.
4. Dynamic face o-rings, item 515, are only required with stainless steel scrapergate supports, item 370, and seal housings, item 500.
5. Seal options include the triple lip seal (shown above), the o-ring seal, and the mechanical seal. Double seal with flush options include the lip seal and o-ring seal. For details, refer to pages 33-353.
6. Rectangular flange models incorporate a bevel seat discharge nozzle.

Item No.	Description	Item No.	Description
011	Rotor	430	Front Cover O-Ring
030	Rotor O-Rings	441	Front Cover Wing Nut
073	Liners	450	Front Cover Stud
100	Scrapergate Guide	500	Seal Housing
125	Scrapergate	510	Lip Seals
231	Shaft Nut	515	Dynamic Face O-Rings
305	Pump Housing	520	Lip Seal Support Rings
370	Scrapergate Support	530	Shaft Sleeve
405	Front Cover	540	Seal Housing O-Ring
420	Front Cover Pin		

Power End

**MR-135RF
MR-150RF**

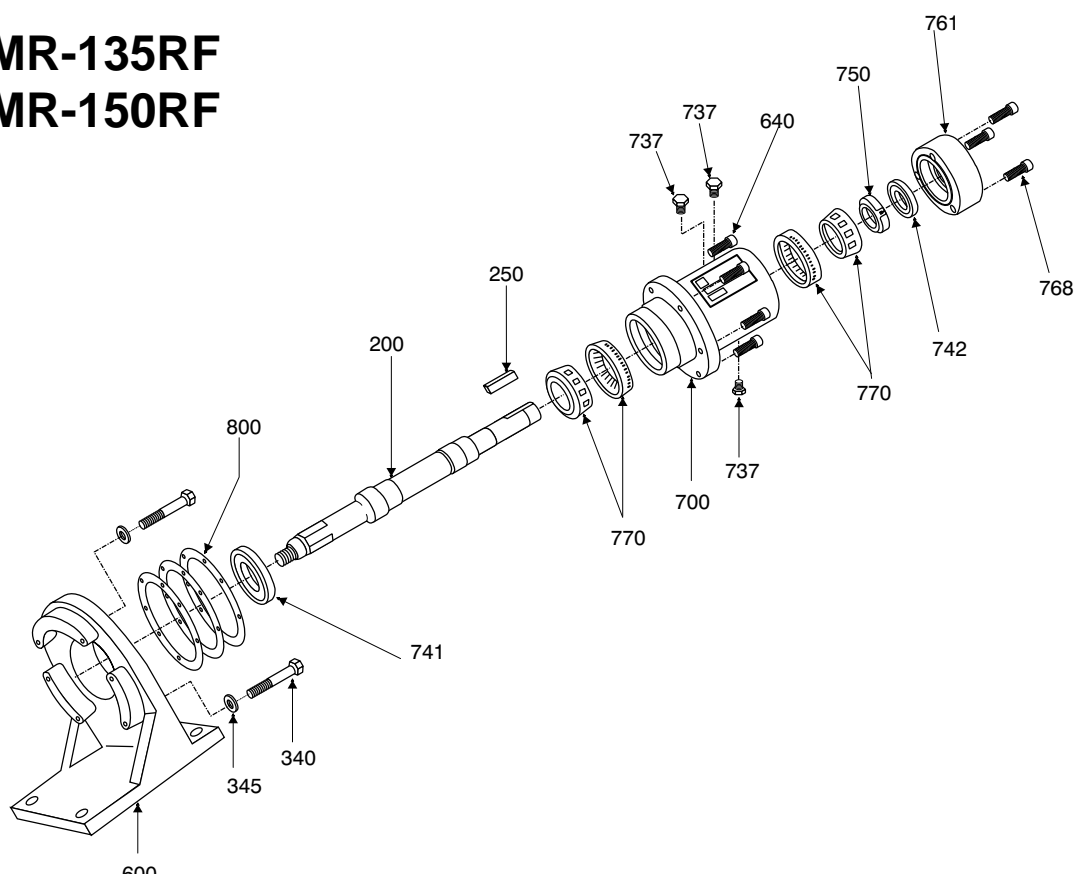

Notes:

1. Shims (Item 800) may vary in both number and thickness.
2. Inboard tapered roller bearing, item 770, on the MR-150 RF is larger than the outboard tapered roller bearing.

Item No.	Description	Item No.	Descriptions
200	Shaft	741	Oil Seal, Inboard
250	Shaft Key	742	Oil Seal, Outboard
340	Housing Mounting Bolts	750	Bearing Lock Nut
345	Housing Mounting Washers	761	Bearing Housing Cover
600	Power Frame	768	Bearing Housing Cover Cap Screw
640	Bearing Housing Mounting Cap Screws	770	Tapered Roller Bearings
700	Bearing Housing	800	Shims
737	Oil Fill/Level/Drain Plugs		

Dimensions – Inches (Millimeters)

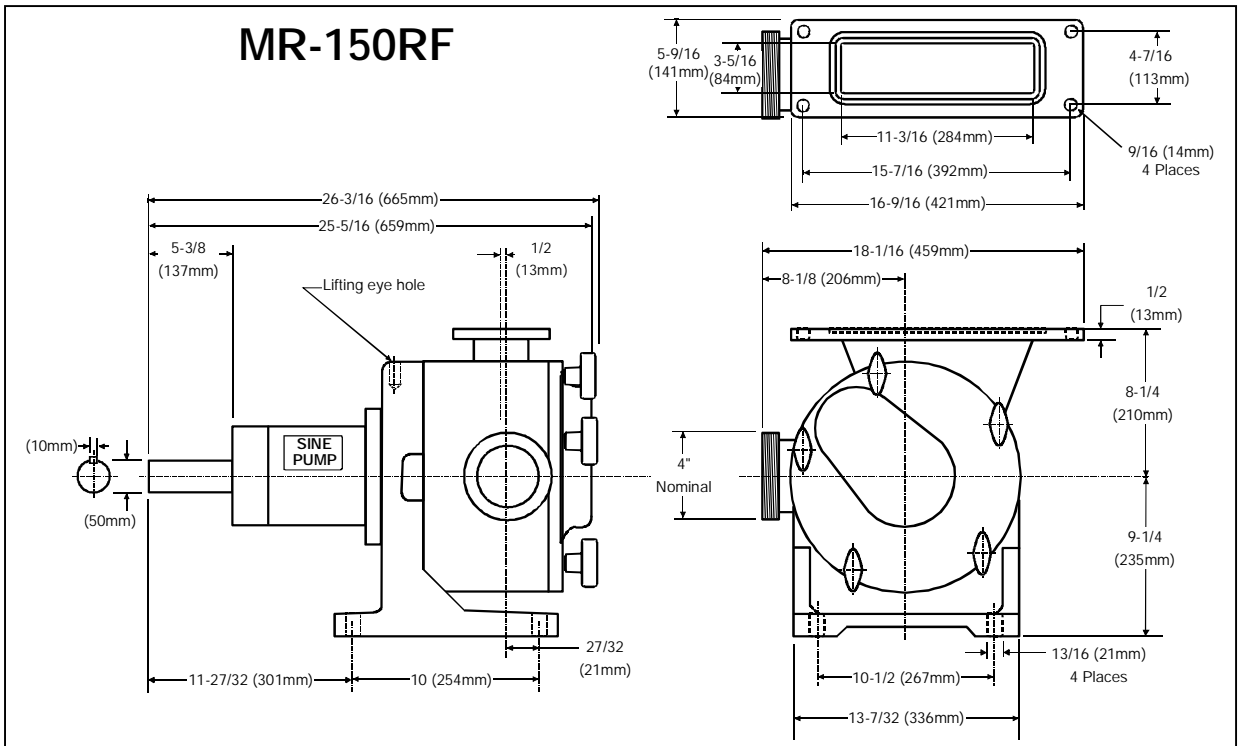
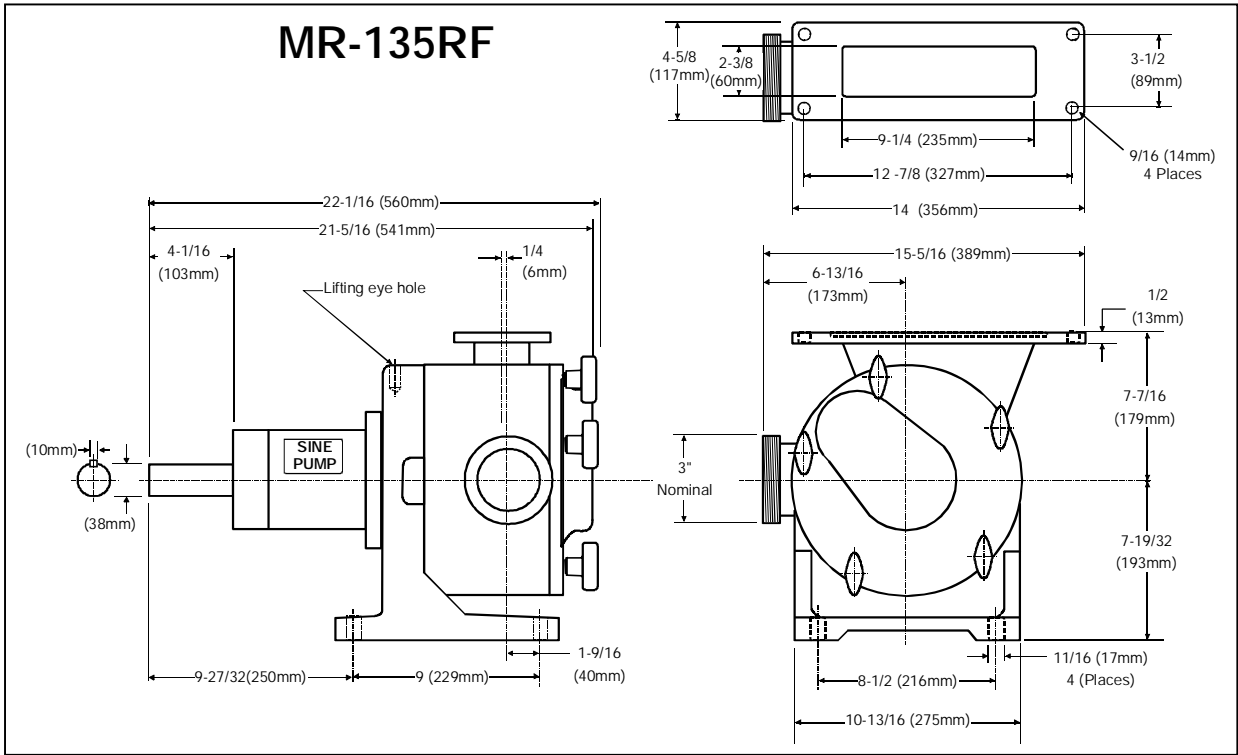

General Notes

MR-120 / SPS-20 - MR-150 / SPS-50 Pumps

- All rotors and certain scrapergates are marked with the symbol **. These are of the MAXRAD design.

MAXRAD scrapergates (Item #125) must be used with MAXRAD rotors (Item # 011). Both are marked in the price book with ** for your convenience. The parts are physically marked with "MR".

SPS design scrapergates must be used with SPS design rotors.

SPS rotors are no longer sold. Any pump can accept a new set of MR scrapergate and MR rotor.

The scrapergate guides are useable with either the MR or the SPS Design scrapergate.

Part Identifier Scheme

MR-120 / SPS-20 - MR-150 / SPS-50 Pumps

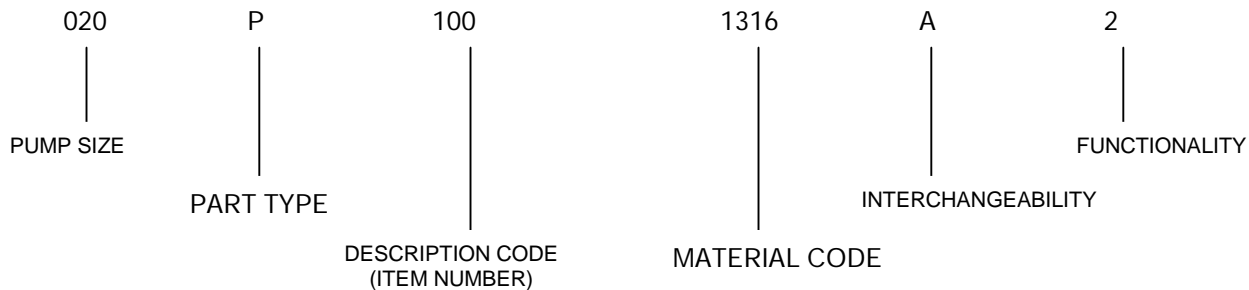

<u>OBSOLETE</u>	<u>PUMP SIZES</u>	<u>MAXRAD SERIES</u>
002=SPS2	020=SPS20	020=MR120
003=SPS3	025=SPS25	025=MR125
004=SPS4	030=SPS30	030=MR130
006=SPS6	035=SPS35	035=RM135
	050=SPS50	050=MR150

PART TYPE
 A - ASSEMBLY
 P = COMPONENT PART
 X = SUBASSEMBLY

DESCRIPTION CODE
 (ITEM NUMBER)
 003 THRU 980
EXAMPLES:
 100 = SCRAPERGATE GUIDE
 125 = MAXRAD SCRAPERGATE

MATERIAL CODE
 1000 - 9030 (SEE MATERIAL CODE LIST FOR DEFINITIONS)
EXAMPLES: 1316 = 316 STAINLESS STEEL
 4400 = VITON

INTERCHANGEABILITY
 A THRU Z

FUNCTIONALITY
 1 THRU 9

Material Codes and Descriptions
MR-120 / SPS-20 - MR-150 / SPS-50 Pumps

<u>Code</u>	<u>Description</u>
1000	Cast Iron
1100	Carbon Steel
1300	Stainless Steel
1303	303 Stainless Steel
1304	304 Stainless Steel
1316	316 Stainless Steel
1354	17-4PH Stainless Steel
1355	17-4PH Stainless Steel
1360	Nitronic 60
2050	Polyethylene (UHMW)
2060	Sinar
2181	Polybutylene Terephthalate (PBT)
2681	Polyetherimide (HTP)
2737	Sinox
4100	Buna
4150	Buna w/Low Friction
4200	EPDM
4400	Viton
9030	Stainless Steel w/Ceramic Oxide-Hardcoat



14845 W. 64TH AVENUE, ARVADA, COLORADO 80007 USA • +1-303-425-0800 • FAX +1-303-425-0896 • www.sundyne.com

• ANSIMAG • GSP • HMD/KONTRO • MASO/SINE • SCMP • COMPRESSORS • SUNDYNE • SUNFLO •